

PART III: EXHIBITS

State Timber Sale Contract
No. 341-15-34
Mill Bound

EXHIBIT B

Page 1 of 3
629-Form 341-203
Revised 06/97

OREGON DEPARTMENT OF FORESTRY

TIMBER SALE OPERATIONS PLAN

(See Page 2 for instructions)

Date Received by STATE: _____

(5) State Brand Information (complete):

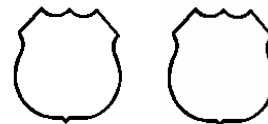

(1) Contract No.: 341-15-34

(2) Sale Name: Mill Bound

(3) Contract Expiration Date: October 31, 2016

Project Completion Dates: _____

(4) Purchaser: _____

(6) Purchaser Representatives:

Projects: _____	Phone: _____	Cell/Other Phone: _____	Home: _____
Projects: _____	Phone: _____	Cell/Other Phone: _____	Home: _____
Projects: _____	Phone: _____	Cell/Other Phone: _____	Home: _____
Projects: _____	Phone: _____	Cell/Other Phone: _____	Home: _____
Logging: _____	Phone: _____	Cell/Other Phone: _____	Home: _____
Logging: _____	Phone: _____	Cell/Other Phone: _____	Home: _____
Logging: _____	Phone: _____	Cell/Other Phone: _____	Home: _____
Road Maintenance: _____	Phone: _____	Cell/Other Phone: _____	Home: _____

(7) State Representatives:

Projects: _____	Phone: _____	Cell/Other Phone: _____	Home: _____
Logging: _____	Phone: _____	Cell/Other Phone: _____	Home: _____

(8) Name of Subcontractors & Starting Dates:

Projects: No(s) _____ - _____	Date: _____	Phone: _____
No(s) _____ - _____	Date: _____	Phone: _____
No(s) _____ - _____	Date: _____	Phone: _____
No(s) _____ - _____	Date: _____	Phone: _____
Logging: Felling _____	Date: _____	Phone: _____
Yarding: _____	Date: _____	Phone: _____

(9) Comments:

(10) Operations Map: Attach a copy of timber sale Exhibit A or other suitable map which plainly shows the items listed on the instruction sheet.

EXHIBIT B
INSTRUCTION SHEET FOR OPERATIONS PLAN

SUBMIT ONE COPY OF PLAN TO STATE

Operations shall be limited to the work shown in the plan until a revised plan or supplemental plan is submitted covering additional work. Compliance with this plan is not in lieu of compliance with any federal requirements related to the federal Endangered Species Act. If STATE has prepared a required Forest Practices Act (FPA) "Written Plan" for operations, PURCHASER shall comply with all provisions of the Written Plan.

Explanation of Item No. (from Page 1)

- (5) All sales require you to use a brand furnished by STATE. If the State brand has not been assigned when the plan is submitted, it will be furnished and assigned later. Complete drawing. If more than one brand is assigned to the sale, complete both drawings.
- (6) The contract requires you to have a designated representative available on the sale area or work location who is authorized to receive in your behalf any notice or instruction given by STATE and to take action in regard to performance under the contract. If logging and project work is widely separated, a representative is required for each.
- (7) The STATE representative will be designated when your plan is approved and is the person who will inspect and issue instructions regarding performance.
- (8) Show names of subcontractors to be used for any or all phases of the operations. If subcontractors are not known, or are changed later, give notification to the STATE representative prior to commencement of work by subcontractor.

Show projected dates for commencement of both projects and logging. If projected dates need to be changed at a later date, notification must be given to the STATE representative by supplemental plan or otherwise, prior to commencement of such operations.

- (10) The STATE representative will furnish extra copies of Exhibit A of the contract for your use in preparing the operations map. The map shall use the following legend and show:
 - 1. Landing locations, approximate setting boundaries, and probable sequence of logging the settings. Number the settings in sequence.
 - 2. Locations of spur roads planned for construction, other than those required by the timber sale contract. Provide spur road specifications.
 - 3. Location of proposed tractor yarding roads. Show if and how marked on the ground.
 - 4. Location of temporary stream crossings.
 - 5. List the sequence of performing project work.
 - 6. Location of rock sources - attach pit development plans.



Cable Landing, with numbers for sequence.



Tractor Landing with alphabetical sequence.

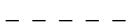

Approximate setting boundary.

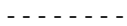

Spur truck roads.



Tractor yarding roads.



Temporary stream crossings.

EXHIBIT B
OPERATIONS PLAN

Completion Timeline

Indicate on the appropriate timeline below, the dates by which you plan to complete the work as required under this contract. The purpose of this section is to develop a plan that will ensure you complete the work as required, and meet the interim completion date(s) and contract expiration date. This plan is incorporated and made a part of the contract. When, in the opinion of STATE, operations are not commencing in a manner that meets the intent of this plan, you may be placed in violation of contract and your operations suspended until an amended plan is submitted and approved by STATE.

Projects

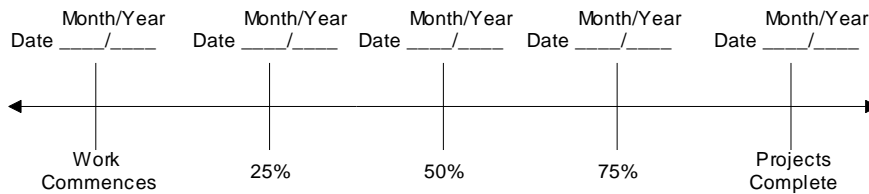

**The
Federal**

Harvest & Other Requirements

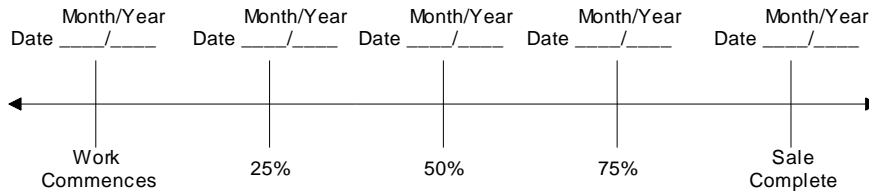

Endangered Species Act (ESA) prohibits a person from taking any federally listed threatened or endangered species. Taking under the federal ESA may include alteration of habitat. STATE's approval of this plan does not certify that PURCHASER's operation under the plan is lawful under the federal ESA. As provided in the timber sale contract, PURCHASERS must comply with all applicable state, federal, and local laws.

PURCHASER's compliance with this plan is not in lieu of compliance with any federal requirements related to the federal Endangered Species Act.

APPROVED: Date: _____

SUBMITTED BY:
PURCHASER

STATE OF OREGON - DEPARTMENT OF FORESTRY

Title _____

Title _____

Original: Salem
cc: District File
Purchaser

EXHIBIT C – SAWMILL GRADE
INSTRUCTIONS FOR FORM 343-307a (rev. 11/11)

- (1) Check appropriate box. REVISION NUMBER requires comments. CANCELLATION requires logging and hauling to be complete, recall branding hammers, date and sign where indicated, write diagonally across page "CANCEL", and send to TPSO.
- (2) Designate Third Party Scaling Organization (TPSO).

Columbia River Log Scaling & Grading Bureau
P.O. Box 7002, Eugene, OR 97401
Phone: (541) 342-6007 Fax: (541) 342-2631
Email: services@crsls.com

Pacific Rim Log Scaling Bureau, Inc.
8288 28th Court North East, Lacey, WA 98516
Phone: (360) 528-8710 Fax: (360) 528-8718
Email: office@prlsb.com

Mountain Western Log Scaling & Grading Bureau
P.O. Box 580, Roseburg, OR 97470
Phone: (541) 673-5571 Fax: (541) 672-6381
Email: info@solsgb.com

Yamhill Log Scaling & Grading Bureau
P.O. Box 709, Forest Grove, OR 97116
Phone: (503) 359-4474 Fax: (503) 359-4476
Email: yamhill@attglobal.net

Northwest Log Scalars, Inc
5526 NE 122nd Ave, Portland, OR 97230
Phone: (503) 254-0600 Fax: (503) 408-0919
Email: info@nwlogscalars.com

Pacific Log Scaling & Grading Bureau, Inc.
P.O. Box 23939, Portland, OR 97281
Phone: (503) 684-5599 Fax: (503) 639-4880
Email: PacLogScale@aol.com

- (3) State District office, address and phone.
- (4) Enter Purchaser's business name, address, and phone number as it appears on the Contract.
- (5) Minimum Scaling Specifications.
- (6) Westside – Region 6 actual taper segment scale. Check Yes or No. Special Service Rules on file with TPSO. See: Segment Scaling and Grading of Long Logs -- All Species -- State Forestry Department Scaling Practices (Westside).
- (7) Weight Scale Sample – Check box if sale is to be a Weight Scale Sample. All specifics for handling, scaling and processing will be attached or explained in the Remarks section Item (15).
- (8) Show scaling locations only applicable to TPSO. Location name should appear as it does on the ODF Approved Scaling Location web site: http://www.odf.state.or.us/DIVISIONS/management/asset_management/ScalingLocation.asp Locations with scaling and processing directions specific to their location should be on a separate form. Species should be identified if not capable of receiving "all" species. Check appropriate box for either: yard, truck scale, or weight. Refer to the web site listed above for the locations approval status.
- (9) Enter sale name and county.
- (10) Enter sale Contract number.
- (11) Enter Oregon's State Brand Registry Number **(REQUIRED)**.
- (12) Show brand assigned to timber sale. One brand only. If more than one brand is assigned to the sale: (1) make a separate form for each brand and (2) on each form, explain and show other brand(s) in the Remarks section Item (15).
- (13) Check yes for Paint Required and designate "Orange" for color. Non required removal volumes may sometimes require blue paint.
- (14) Special Requests. These are requests that will be applied to ODF timber sales. All boxes applicable to the timber sales designated in the Exhibit C form must be "marked". If "Other" is indicated, it must contain a description and any necessary comments.
- (15) Use this space to designate any weight conversion factors, per load volumes, weight scale sample instructions or any other explanations to clarify scaling, processing and/or mailing requirements. If additional scaling locations are approved, revise original or current form showing all (old and new) locations. Check REVISION box at top of form and explain under remarks. Route as indicated.
- (16) Require purchaser to sign and date completed form in addition to State Forester Representative, sign and print name on the form.

Salem Distribution Instructions: Original will be mailed to Salem after it is electronically scanned and placed in the Salem transfer drive <\\WPODFILL01\Transfer\ScalingInstructions> or e-mailed directly to scaling@odf.state.or.us. Scaling instructions for each brand should be scanned separately, for each approved TPSO.

EXHIBIT C – PULP SORT

PROCESSING INSTRUCTIONS -- LOCATION APPROVAL -- BRAND INFORMATION

(1) ORIGINAL REGISTRATION Date _____
REVISION NUMBER _____ Date _____
CANCELLATION Date _____

(2) TO: _____
(Approved Pulp Processing Facility)

(3) FROM: Tillamook (06) Phone 503-842-2545
(State Forestry District)

(4) PURCHASER: _____

(5) Scaling Bureau (TPSO) Processing Weight receipts:

Mailing Address: _____

Phone Number: _____

(9) SALENAME: Mill Bound

COUNTY: Tillamook

(10) STATE CONTRACT NUMBER: 341-15-34

(11) STATE BRAND REGISTRATION NUMBER _____

(12) STATE BRAND INFORMATION: (COMPLETE BELOW)

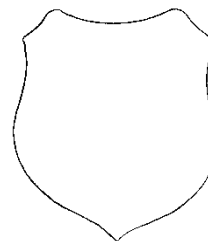

(6) **STATE Definition of Approved Pulp Sort:**

- Top portion of the tree (tops).
- All logs with a diameter (Big End) greater than 8 inches marked with blue paint.

(13) REMARKS: _____

(7) PULP FACILITY PROCESSING INSTRUCTIONS:

- Pulp loads shall be weighed in lieu of scaling.
- One Ton = 2000 lbs (Short Ton).
- Pulp loads shall have a yellow Log Load Receipt attached.
- Gross weight and truck tare weight for each load shall be machine printed on the weight receipt.
- Weigher shall sign the weight receipt.
- Weigher shall record the Log Load Receipt number on the weight receipt.
- Weigher shall attach the Weight receipt to the Log Load Receipt and mail them weekly to the TPSO processing the Weight receipt.

Operator's Name (Optional inclusion by District):

(14) SIGNATURES:

Purchaser or Authorized Representative Date

State Forester Representative Date

State Forester Representative PRINT NAME

(8) TPSO PROCESSING INSTRUCTIONS

- Mail to ODF weekly.
- Convert to mbf using 10 tons per mbf.

Notify the District within one hour when branding is inadequate for quick identification, the logs are marked with orange paint, the receipts are missing, not correctly or completely filled out, and/or logs do not meet the specifications of the STATE definition of Approved Pulp Sort.

Distribution: ORIGINAL: Salem / COPIES: TPSO, Approved Pulp Processing Location, Purchaser, District, Mgmt. Unit

EXHIBIT C – PULP SORT
INSTRUCTIONS FOR FORM 343-307b (rev. 11/11)

- (1) **Must Complete.** Check appropriate box. REVISION NUMBER requires comments in the Remarks Section (13). CANCELLATION requires logging and hauling to be complete, recall branding hammers, date and sign where indicated, write diagonally across page "CANCEL", and send to TPSO.
- (2) **Must Complete.** Approved Pulp Processing Facility. Write in as written in the Approved Log Delivery Location http://www.odf.state.or.us/DIVISIONS/management/asset_management/ScalingLocation.asp
- (3) **Must Complete.** State Forestry District and District Phone Number.
- (4) **Must Complete.** Purchaser's business name as it appears on the Contract.
- (5) **Must Complete.** Third Party Scaling Organization that will be processing the weight tickets, mailing address, and phone number.

Columbia River Log Scaling & Grading Bureau
P.O. Box 7002, Eugene, OR 97401
Phone: (541) 342-6007 Fax: (541) 342-2631
Email: services@crls.com

Pacific Rim Log Scaling Bureau, Inc.
8288 28th Court North East, Lacey, WA 98516
Phone: (360) 528-8710 Fax: (360) 528-8718
Email: office@prlsb.com

Mountain Western Log Scaling & Grading Bureau
P.O. Box 580, Roseburg, OR 97470
Phone: (541) 673-5571 Fax: (541) 672-6381
Email: info@solsgb.com

Yamhill Log Scaling & Grading Bureau
P.O. Box 709, Forest Grove, OR 97116
Phone: (503) 359-4474 Fax: (503) 359-4476
Email: yamhill@attglobal.net

Northwest Log Scalars, Inc .
5526 NE 122nd Ave, Portland, OR 97230
Phone: (503) 254-0600 Fax: (503) 408-0919
Email: info@nwlogscalars.com

Pacific Log Scaling & Grading Bureau, Inc.
P.O. Box 23939, Portland, OR 97281
Phone: (503) 684-5599 Fax: (503) 639-4880
Email: PacLogScale@aol.com

- (6) **Must Complete.** Big end log not to exceed _____ inches. Big end of log is not to exceed 2 inches greater than the minimum removal specifications in the contract. Example: Minimum removal specifications 6 inches and 20 board feet, then the Big end of log not to exceed 8 inches. When conifer and hardwood removal specifications are different, use the smaller removal diameter to determine this specification.
- (9) **Must Complete.** Enter sale name and county. If more than one county write in all the counties that the sale is located in.
- (10) **Must Complete.** Enter sale Contract number.
- (11) **Must Complete.** Enter Oregon's State Brand Registry Number **(REQUIRED)**.
- (12) **Must Complete.** Show brand assigned to timber sale. One brand only. If more than one brand is assigned to the sale: (1) make a separate form for each brand and (2) on each form, explain and show other brand(s) in the Remarks section Item (13).
- (13) Use this section to list any special instructions or the reason for any revisions in section item (1).
- (14) **Must Complete.** Purchaser required to sign and date completed form in addition to State Forester Representative, sign and print name on the form.

Salem Distribution Instructions: Original will be mailed to Salem after it is electronically scanned and placed in the Salem transfer drive \\WPODFILL01\Transfer\ScalingInstructions or e-mailed directly to scaling@odf.state.or.us . Scaling instructions for each brand should be scanned separately, for each approved TPSO.

EXHIBIT D
 FOREST ROAD SPECIFICATIONS

SUBGRADE WIDTH (feet)	SURFACED WIDTH (feet)	POINT TO POINT	STATION TO STATION	DRAINAGE	Ditch Shape	Ditch Top Width (feet)	Ditch Depth (feet)
16 feet	12 feet	A to B	0+00 to 573+49	Ditch	V	3	1
16 feet	12 feet	A to B	*	Outslope /Ditch	V	3	1
16 feet	12 feet	C to D	0+00 to 22+19	Outslope	---	---	---
16 feet	12 feet	E to F	0+00 to 9+46	Outslope	---	---	---
16 feet	12 feet	G to H	0+00 to 63+41	Outslope	---	---	---
16 feet	12 feet	I to J	0+00 to 11+40	Outslope	---	---	---

*Outslope road in areas of live water as marked in field.

CLEARING. This work shall consist of clearing, removing, and disposing of all trees, snags, down timber, brush, surface objects, and protruding obstructions within the clearing limits. Trees outside the clearing limits shall not be felled unless approved in writing by STATE. All danger trees, leaners, and snags outside the clearing limits which could fall and hit the road shall be felled. Where clearing limits have not been marked, clearing limits shall be as follows:

- New construction – 10 feet back from the top of the cut slope and 5 feet back from the toe of fill slopes.
- Improvements and reconstructions – As marked in field or directed by STATE.

GRUBBING. This work shall consist of the removal or digging out of stumps and protruding objects. All stumps shall be completely removed within the limits of required grubbing. Stumps overhanging cutslopes shall be removed. Grubbing limits shall be as follows:

- New construction - From the top of the cutslope to the toe of the fill.
- Improvements and reconstructions - 4 feet back from the shoulder of the subgrade or the ditch, whichever is widest.

CLEARING AND GRUBBING DISPOSAL. Clearing and grubbing debris shall not be placed or permitted to remain in or under any road embankment sections. Clearing and grubbing debris shall not be left lodged against standing trees. Clearing and grubbing debris may be scattered through openings in the timber outside of the cleared right-of-way, except for the following areas where debris shall be fully contained and hauled to a designated waste area:

- Where end-haul is required
- On side slopes exceeding 55 percent
- On unstable areas
- In any stream channel (Type F, N or D) or where material may enter the stream channel.

Clearing, grubbing, and associated disposal shall be completed prior to subgrade approval.

EXHIBIT D

FOREST ROAD SPECIFICATIONS

EXCAVATION. Excavation and grading shall not be done when weather and/or ground conditions are such that damage will result to existing subgrade or cause excessive erosion.

Excavation shall conform to STATE-specified lines, grades, dimensions, and plans when provided.

Suitable excavated material shall be used for the formation of fills, shoulders, and drainage structure backfills. Embankment materials shall be free of woody debris, brush, muck, sod, frozen material, and other deleterious materials. All fills and drainage structure backfills shall be machine compacted according to the "Compaction and Processing Requirements" in Exhibit E.

Unless road plans show otherwise, all roads shall be on a balanced cross section, except when the slope is over 55 percent, the road shall be on full bench for the width specified.

Sidecast includes any road generated excess excavation material which is not essential as part of the road prism, is not compacted, and is below the roadway. Sidecast shall not be placed where it will enter a stream course or where material will accumulate in areas deemed a high landslide hazard location by STATE. Leaving sidecast below the road is only permissible if specifically allowed in "Full Bench and End Haul Requirements" in this Exhibit.

ROAD WIDTH LIMITATIONS. PURCHASER shall obtain advance written approval from STATE to construct the road to a greater width than specified. Extra subgrade width shall be required for:

Fill Widening. Add to each fill shoulder 1 foot for fills 3 feet to 6 feet high; 2 feet for fills over 6 feet high.

Curve Widening. Widen the inside shoulder of all curves as specified in the road plans or as follows: 400 divided by the radius of the curve equals the amount of extra width.

DRAINAGE

Ditch. Construct ditch as specified in Exhibit D. Subgrade shall be crowned at 4 to 6 percent. Construct ditchouts away from subgrade at locations marked in the field or as directed by STATE.

Outslope. Road subgrade shall be outsloped at 4 to 6 percent.

TURNOUTS. Increase roadbed width an additional 8 feet for both subgrade and surfacing. Length shall be at least 25 feet, or as staked on the ground, plus 25-foot approaches at each end.

Location: Intervisible but not greater than 750 feet apart.

SLOPES

Rock
Common

Back Slopes
Vertical to 1/4 :1
3/4 :1

Fill Slopes
Not Steeper
Than 1 1/2: 1

Top of cutslopes shall be rounded.

LANDINGS. Landings shall be constructed as posted in the field, no less than 50 feet wide and no more than 70 feet wide unless otherwise approved by STATE. Surface is to be crowned for drainage with general grade no more than 4 percent and no less than 2 percent. All cuts shall be ditched. Surface the landing as shown in the "Road Surfacing" table in Exhibit E.

TURNAROUNDS. Increase subgrade width an additional 30 feet for a length of 16 feet with 20' radius returns at locations marked in the field.

SEASONAL WINTERIZATION. All unsurfaced roads or unfinished subgrades shall be waterbarred in accordance with the specifications in Exhibit H, and blocked from vehicular traffic prior to October 31, annually and as directed by STATE.

EXHIBIT D
ROAD BRUSHING SPECIFICATIONS



Clearing Limits

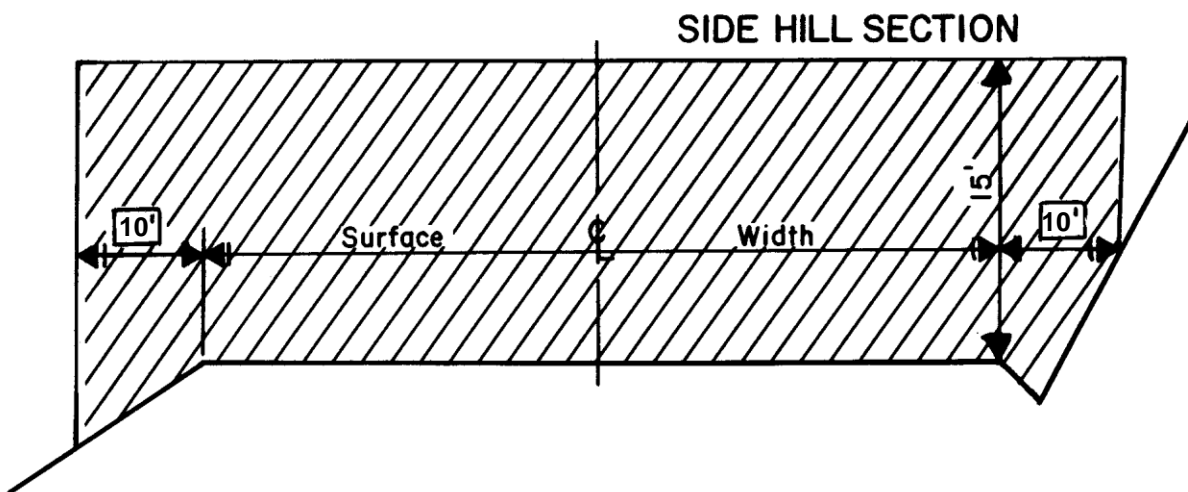

REQUIREMENTS

Unless otherwise approved in writing by STATE, brush and trees shall be cut to a height of 6 inches or less above the ground surface or obstructions such as rocks or existing stumps. Trees 8 inches or larger in diameter at stump height shall not be felled but shall be limbed for road visibility. Brushing on project road segments shall be completed prior to subgrade approval. Trees shall not be felled unless a portion of the bole is within the clearing limits.

Debris resulting from the brushing operation shall be removed from the roadway, cutslope, ditches, and water courses within 72 hours and may be scattered downslope from the road or placed in other stable locations, unless otherwise approved by STATE.

Trees outside the clearing limits shall not be felled unless approved in writing by STATE.

CULVERT AND ROAD MARKER DAMAGES. Culvert and road markers damaged, or any portion of a marker damaged from PURCHASER activities shall be repaired or replaced by PURCHASER.

EXHIBIT D

FOREST ROAD SPECIFICATIONS

ADDITIONAL ROAD INSTRUCTIONS

A to B

29+00 to 35+60 – Remove approximately 200 c.y. slump from cutslope. End haul to “Waste Area 1”.

61+70 – Install free drain: Excavate trench across road 34' long, 18' wide, and 18" deep from base of current subgrade. Trench should be level from side to side, and be sloped at 5% towards edge of fill slope. Install 3.5 oz. nonwoven geotextile along the trench and fill trench with 8" of drain rock. Geotextile should be laid so it can completely encase the drain rock and have 1' of overlap on top. Apply 8" of new base rock and 4" of new crushed rock to surface of road.

67+10 - Lower road surface elevation on north side of bridge so road drains away from bridge.

92+92 – Place 100 c.y of levelling rock. Spread rock 4' wider than current road surface.

190+70 to 192+00 – Fill ditch/trail approach with 40 c.y. of rock for better low boy access across bridge.

270+90 - Lower road surface elevation on both sides of bridge so road drains away from bridge.

342+50 - Lower road surface elevation on north side of bridge so road drains away from bridge.

E to F

2+00 to 2+45 – Pullback sidecast and widen road in accordance with specifications in Exhibit N.

G to H

0+00 to 7+14 – Fill in ditch with rock, outslope road.

EXHIBIT D

FULL BENCH AND END-HAUL REQUIREMENTS

POINT TO POINT	STA. TO STA.
A to B	29+00 to 35+60
C to D	9+10 to 11+21
C to D	11+50 to 13+62
E to F	2+00 to 2+45
G to H	43+59 to 59+75

Full Bench and End-Haul Areas General Requirements

Sidecast includes any road generated excess excavation material which is not essential as part of the road prism, is not compacted, and is below the roadway. Material shall not be sidecast unless specified above.

Clearing and grubbing debris shall be end-hauled.

When controlled blasting is required, it shall be accomplished using timing devices, delayed charges, low intensity shots, or other suitable means to contain material within the road prism.

Containment/Sidecast

Full Containment: Sidecast material lost over the outside edge of the road shall not exceed 6 inches in depth, measured perpendicular to the natural ground slope. Pioneer excavation shall be removed by digging, loading, and hauling rather than by pushing or scraping methods.

Tree bases and stumps may have up to 12 inches of material directly above them.

Any amount of material exceeding the containment requirements shall be removed by whatever means necessary and end-hauled to a designated waste area.

Waste Area Location

As shown on Exhibit A and as marked in the field.

Waste Area Treatment

- (1) Deposit at waste area, spread evenly, compact, and provide adequate drainage.
- (2) Pile woody debris separate from other waste material.
- (3) Seed all waste areas in accordance with Exhibits K and L.

EXHIBIT E
 ROAD SURFACING

ROAD SEGMENT: A to B			STATIONS: 0+00 to 573+49						
Application	Rock Size and Type	Location	Compacted Depth	Volume (CY) per	Number of Units	Curve Widening (CY)	Approx. Total (CY)		
Road Rock	Crushed 1 1/2"-0"	0+00 to 573+49	4 "	station 20.070	573.49	520	12,030		
Turnouts	Crushed 1 1/2"-0"	A to B	4 "	TO 10	77		770		
Application	Rock Size and Type	Location	Approx. Total (CY)						
Junction Rock	Crushed 1 1/2"-0"	0+00, 9+10, 272+30, 488+90	110						
French Drain Rock	Drain Rock 3"-1"	61+70	50						
Base Rock	Jaw-Run 4"-0"	61+70	20						
Surface Rock	Crushed 1 1/2"-0"	61+70	30						
Levelling Rock	Crushed 1 1/2"-0"	92+00, 129+50, 312+50	130						
Culvert Backfill	Crushed 1 1/2"-0"	*	100						
Widening Rock	Crushed 1 1/2"-0"	190+70	40						

ROAD SEGMENT: C to D			STATIONS: 0+00 to 22+19						
Application	Rock Size and Type	Location	Compacted Depth	Volume (CY) per	Number of Units	Curve Widening (CY)	Approx. Total (CY)		
Road Rock	Jaw-Run 4"-0"	4+10 to 22+19	8 "	station 42.012	18.09	40	800		
Turnouts	Jaw-Run 4"-0"	C to D	8 "	TO 20	3		60		
Application	Rock Size and Type	Location	Approx. Total (CY)						
Tumaround Rock	Pit-Run 6"-0"	16+77	40						
Landing Rock	Pit-Run 6"-0"	22+19	40						

ROAD SEGMENT: E to F			STATIONS: 0+00 to 13+70						
Junction Rock	Crushed 1 1/2"-0"	0+00					20		

ROAD SEGMENT: G to H			STATIONS: 0+00 to 63+41						
Application	Rock Size and Type	Location	Compacted Depth	Volume (CY) per	Number of Units	Curve Widening (CY)	Approx. Total (CY)		
Road Rock	Jaw-Run 4"-0"	40+73 to 63+41	8 "	station 41.887	22.68	50	1,000		
Road Rock	Jaw-Run 4"-0"	0+00 to 40+73	8 "	station 41.738	40.73	80	1,780		
Turnouts	Jaw-Run 4"-0"	G to H	8 "	TO 20	4		80		
Turnouts	Jaw-Run 4"-0"	G to H	8 "	TO 20	6		120		
Application	Rock Size and Type	Location	Approx. Total (CY)						
Tumaround Rock	Pit-Run 6"-0"	62+00	40						
Landing Rock	Pit-Run 6"-0"	63+41	120						

ROAD SEGMENT: I to J			STATIONS: 0+00 to 11+40						
Application	Rock Size and Type	Location	Compacted Depth	Volume (CY) per	Number of Units	Curve Widening (CY)	Approx. Total (CY)		
Road Rock	Jaw-Run 4"-0"	0+00 to 11+40	12 "	station 65.789	11.40	40	790		
Turnouts	Jaw-Run 4"-0"	I to J	12 "	TO 30	2		60		
Application	Rock Size and Type	Location	Approx. Total (CY)						
Tumaround Rock	Pit-Run 6"-0"	9+00	40						
Landing Rock	Pit-Run 6"-0"	11+40	40						

*As marked in field (10 cubic yards for each culvert to be installed)

EXHIBIT E
ROAD SURFACING

TOTAL ROCK	6"-0" PIT-RUN	4"-0" CRUSHED	3"-1" CRUSHED	1 ½"-0" CRUSHED
19360 CY	320 CY	4710 CY	50 CY	14230 CY

Roads shall be uniformly graded and approved by STATE prior to rocking.
Additional rock for curve widening is required and has been included in the volume estimates.
Turnouts, turnarounds, landings and junctions shall be rocked concurrently with the road.
Any additional turnarounds or turnouts created during any operation associated with this timber sale shall be rocked at PURCHASER's expense and as instructed by STATE.

For typical cross section, turnout and turnaround see Forestry Department Drawing Nos. 351-C, 351-D and TOTA-1 at the Forestry Department district office.

EXHIBIT E

CRUSHED ROCK SPECIFICATIONS

Materials. The material shall be fragments of rock crushed to the required size. The material shall be free from vegetation and lumps of clay. STATE may require screening and/or rejecting of materials utilized for production of crushed rock for the purpose of removing excess fine material. Excess fines are present, when greater than 5 percent of a total rock sample weight, passes a #200 sieve. Rock crushing shall be limited to periods when weather conditions are acceptable to STATE.

Quality and Grading Requirements. The base material shall be rock. River gravel shall not be used. Crushed rock shall meet the grading requirements that follow:

Hardness - Test Method AASHTO T 96: 30% Maximum

Durability - Test Method ODOT TM 208
Passing No. 20 Sieve: 30% Maximum

For the purpose of crushing the 1 ½"-0" rock specified under the projects in Section 2610, "Project Work," PURCHASER shall utilize a **three-stage** rock crusher, or equivalent.

The rock crusher shall be calibrated to produce rock as specified in this exhibit. Prior to the commencement of production crushing, PURCHASER shall sample, test, and provide rock test results meeting STATE specifications. STATE may then sample and test crushed rock for approval to proceed. PURCHASER shall take one sample of each 2,000 cubic yards of crushed rock material produced thereafter, using approved AASHTO sampling procedures. PURCHASER shall submit samples to a certified laboratory or shall perform testing for gradation requirements using AASHTO T 11 and AASHTO T 27 testing procedures. Prior to testing, each sample shall be split, making one-half of the sample, with proper identification, available for testing by STATE. Each sample and the results of PURCHASER testing shall be made available to STATE within 24 hours of sampling. Any rock crushed prior to STATE approval to proceed shall not be credited to the required rock quantity. Any subsequent rock tests not meeting STATE specifications shall be reason for rejection of that portion of crushed rock produced after that test and shall not be credited to the required rock quantity. STATE may sample the crushed rock at any time during the operation. Results of STATE's tests shall prevail over all other test results.

For 1 ½"-0" Crushed

Sieve size	Percent Passing
	1.5 " inch
4	--
3	--
2	100
1.5	95-100
1	--
3/4	70-90
1/4 or #4	40-60
#10	30-50
#40	10-20

EXHIBIT E
CRUSHED ROCK SPECIFICATIONS

<u>For 4"-0" Jaw-Run</u>	Passing	4" sieve	95%
	Passing	2" sieve	40-60%
	Passing	1/4" sieve	10% maximum
<u>For 6"-0" Pit-Run</u>	Passing	10" sieve	100%
	Passing	6" sieve	60-85%
	Passing	3" sieve	30-50%
	Passing	1/4" sieve	10% maximum
<u>For 3" – 1" Drain Rock</u>	Passing		3" sieve
	100%		
	Passing		1.5" sieve
	5-20%		
Passing		3/4" sieve	
0-5%			

Control of pit-run gradation shall be by visual inspection by STATE. Pit-run shall be reasonably free of organic material and shall not contain an excessive amount of oversized (cobbles or boulders) or undersized (clay, silt or sand) particles.

The referenced sieve shall have square openings as set forth in AASHTO M 92, Woven Cloth Series. The determinations of size and gradings shall be as set forth in AASHTO T 27.

EXHIBIT E

ROCK ACCOUNTABILITY

PURCHASER shall obtain subgrade approval from STATE prior to rocking. Rocking shall be limited to periods when weather conditions are acceptable to STATE and when sediment will not enter streams. Additional surfacing needed because of construction season or construction practice is not included in the preceding ROAD SURFACING table, and shall be furnished at PURCHASER expense.

Rock accountability shall be determined by depth measurement. STATE shall be given 24 hours' notice prior to rocking.

Depth Measurement. Rock shall be spread and compacted according to the depths specified in Exhibit E. Truck measure volumes are given, but shall not limit the amount of rock spread. Depth shall be determined in the most compacted area of the surface cross section. The depth of compacted aggregates shall not vary more than 1 inch from the depth specified in the "Road Surfacing" table in Exhibit E. The average depth for each road segment shall be the specified depth or greater. If additional rock is required because of insufficient depth, the locations and volumes to be added shall be determined by STATE. The conversion from compacted yardage to truck yardage is 1.3 multiplied by the compacted yardage equals truck yardage.

Turnouts shall have a surfaced area of at least 44 square yards each at the depths shown in Exhibit E.

Turnarounds shall have a surfaced area of at least 73 square yards each at the depths shown in Exhibit E.

Landings shall have a minimum surfaced area of at least 220 square yards each at the depths shown in Exhibit E.

Curve Surfacing. Extra surface width shall be required for the inside of all curves as follows: 400 divided by the radius of the curve equals the amount of extra width to be surfaced at the depths shown in Exhibit E.

EXHIBIT E

COMPACTION AND PROCESSING REQUIREMENTS

Moisture Content: Compaction must take place when moisture content of the materials being compacted is favorable for effective compaction as determined by STATE.

Compaction Pass: A pass is defined as traveling a road section forward and then backward over that same section.

Subgrade. Subgrade surfaces of the road segments listed below shall be graded and compacted prior to rocking. Compaction shall be accomplished by traveling all surfaces from shoulder to shoulder until the surface is smooth and hard and visible deformation ceases or in the case of a sheepsfoot roller, the roller "walks out." At least 3 passes shall be made over the entire width and length of the road. Compaction shall be accomplished by using one or more of the approved equipment options listed below:

Subgrade shall be crowned, or outsloped at 4 to 6 percent as specified in the "Forest Roads Specifications" table in Exhibit D.

ROAD SEGMENT	COMPACTION EQUIPMENT OPTIONS
A to B, C to D, E to F, G to H, and I to J	Vibratory Roller

Pit-Run Rock. Pit-run surfacing rock shall be spread on roads with a crawler tractor and continuously walked-in. Rock spreading shall begin at nearest point from the rock source and progress toward the end of the project, unless otherwise approved in writing by STATE. Compaction shall be accomplished by using the approved equipment listed below or others approved by STATE:

Rock shall be compacted and processed during the same project period it is spread, unless otherwise approved in writing by STATE.

Rock shall be crowned or outsloped at 4 to 6 percent unless otherwise specified.

ROAD SEGMENT	COMPACTION EQUIPMENT OPTIONS
C to D, E to F, G to H, and I to J	Vibratory Roller

Crushed Rock. The rock shall be uniformly mixed and spread in layers on the approved roadbed. Each layer of crushed rock shall be moistened or dried to uniform moisture content suitable for maximum compaction and compacted in layers not to exceed 6 inches in depth. When more than 1 layer is required, each shall be shaped and compacted before the succeeding layer is placed. Any irregularities or depressions that develop during compaction of the top layer shall be corrected by loosening the material at these places and adding or removing material until the surface is smooth and uniform. Each layer shall be compacted with a minimum of 3 passes over the entire width and length of the road until the surface is smooth and hard and visible deformation ceases. Compaction shall be accomplished by using one or more of the approved equipment options listed below:

Rock shall be compacted and processed during the same project period it is spread, unless otherwise approved in writing by STATE.

Rock shall be crowned at 4 to 6 percent as specified in the "Forest Roads Specifications" table in Exhibit E.

ROAD SEGMENT	COMPACTION EQUIPMENT OPTIONS
A to B	Vibratory Roller

EXHIBIT E

COMPACTION AND PROCESSING REQUIREMENTS

Existing Crushed Rock. The existing rock shall be unearthed to a minimum depth of 4 inches or to 1 inch below the bottom of potholes, whichever is greater. The existing rock shall then be uniformly mixed and moistened or dried to a uniform moisture content suitable for maximum compaction and compacted. Any irregularities or depressions that develop during compaction shall be corrected by loosening the material at these places and adding or removing material until the surface is smooth and uniform. The existing rock shall be compacted with a minimum of 3 passes over the entire width and length of the road. Compaction shall be accomplished by using the approved equipment listed below or others approved by STATE:

Existing crushed rock shall be compacted and processed after completion of all project work and log hauling, unless otherwise approved in writing by STATE.

Rock shall be crowned at 4 to 6 percent unless otherwise specified.

ROAD SEGMENT	COMPACTION EQUIPMENT OPTIONS
A to B	Vibratory Roller

COMPACTION EQUIPMENT OPTIONS

Vibratory Rollers. The drum shall have a smooth surface, a diameter not less than 48 inches, a width not less than 58 inches, and a turning radius of 15 feet or less. (*Vibration frequency shall be regulated in steps to 1400, 1500, and 1600 VPM, corresponding to engine speeds of 1575, 1690, and 1800 RPM. The centrifugal force developed shall be 7 tons at 1600 VPM. It shall be activated by a power unit of not less than 25 horsepower.) The vibratory roller shall be self-propelled and operated at speeds ranging from 0.9 miles to 1.8 miles per hour, as directed by STATE.

Rubber-Tired Skidders. A rubber-tired skidder weighing a minimum of 20,000 pounds shall be operated over the fill layers so that the entire layered surface comes in contact with the tires. Skidders with oversized tires (high flotation) are not acceptable for compaction.

Tampingfoot Compactors. Tampingfoot compactors shall exert a minimum pressure of 250 pounds per square inch on the ground area in contact with the tamping feet. The compactor shall cover a minimum width of 60 inches per pass and weigh a minimum of 16,000 pounds.

Vibratory Hand-Operated or Backhoe-Mounted Tamper. Vibratory hand-held or hydraulic tampers shall be used for compaction of backfill materials around culverts (and/or bridge approach embankment materials around abutments). The tamper shoe dimensions shall be a minimum of 10" X 13" and capable of a centrifugal force of 2,250 pounds.

Vibratory Grid Compactors. The roller shall have a grid surface and have an operating weight of 32,000 pounds or more. The rock shall be worked with a grader weighing at least 20,000 pounds during the grid rolling process. All rock shall come in contact with the vibratory grid compactor.

Grid Rollers. Pit-run rock shall be processed by grid roller fully equipped with 32,000 pounds or more of ballast weights. Twenty passes shall be made with a grid roller over the entire length and width of the road, unless STATE requires fewer passes. A grader weighing at least 20,000 pounds shall work the pit-run surface during grid rolling so that all pit-run rock comes in contact with the grid roller. Grid rolling shall be performed when the subgrade is dry and firm. Road surface shall be uniformly shaped and graded prior to and during grid rolling.

Loaded Dump Trucks. Dump trucks shall be routed over the entire cross section of the road surface. Loaded trucks shall cover all of the subgrade with a minimum of three passes.

Crawler Tractors. D-7 Caterpillar or equivalent.

EXHIBIT F

ROCK QUARRY DEVELOPMENT AND USE

1. PURCHASER shall prepare a written development plan for the quarry area. The plan shall be submitted to STATE for approval prior to conducting any operation in quarry area. The plan shall include, but not be limited to:
 - (a) Location of quarry floor, benches, and roads to benches.
 - (b) Disposal site for woody debris, overburden and reject material.
 - (c) Time lines for rock quarry use.
 - (d) Erosion control measures.
 - (e) Oversize material location.
2. PURCHASER shall schedule and coordinate quarry and stockpile usage with other existing or planned activity requiring quarry or stockpile usage. **PURCHASER shall notify STATE 5 days prior to the start of quarry development activities.**
3. Fall all timber within the posted right-of-way boundary and remove all merchantable timber. All woody debris, including stumps and slash shall be hauled to the designated disposal areas.
4. Where overburden removal limits have not been marked, they shall extend for a distance of at least 20 feet beyond the developed rock source. Overburden removal limits, when marked, are designated by orange right-of-way boundary tags. Overburden shall be hauled to a designated waste area. Overburden shall be spread evenly, grass seeded, and compacted at the waste area and woody debris stacked separately. Areas of overburden removal shall be inspected for completeness and approved by STATE prior to drilling or rock removal. At "Property Line Pit" existing piles of overburden material and clearing debris shall be hauled to waste area.
5. PURCHASER shall conduct the Operations relative to the disposal of waste material in such manner that silt, rock, debris, dirt, or clay shall not be washed, conveyed, or otherwise deposited in any stream. All waste shall be deposited at an approved "waste disposal site."
6. The quarry floor shall be developed to provide drainage away from the quarry. All quarry and stockpile site drainage ditches shall be developed and maintained. Drainage ditches shall not discharge into streams.
7. Benches shall be constructed and maintained at intervals of 40 feet or less in height and shall be a minimum of 20 feet in width. Any gravel or talus slopes shall be left with a working face at an angle of 60 percent or less. There shall be a minimum of one bench with an access road to it. Said bench shall be easily accessible with tractors.
8. The STATE shall be notified two working days prior to the beginning of drilling operations. Working days shall be defined as Monday through Friday, 6:00 a.m. to 2:30 p.m.
9. Controlled blasting techniques shall be utilized for any blasting operations, and shall be accomplished using timing devices, delayed charges, low intensity shots, or other suitable means to contain as much material as possible within the quarry development area (full containment). Each low intensity shot shall be shot into the previous shots' void in order to contain all the material in the quarry development area. Each shot shall also have a "tattle-tale" end cap so that it is known if all charges were detonated. The purchaser shall detonate or remove all non-detonated explosives from STATE LANDS. PURCHASER shall maintain a comprehensive blasting log that contains all pertinent data for all blasting operations. The blasting log shall be submitted to the STATE after the completion of all blasting activity. The blasting log is intended for STATE record keeping purposes only.

EXHIBIT F

ROCK QUARRY DEVELOPMENT AND USE

10. Quarry face shall be developed in a uniform manner. All quarry backslopes shall be left in a stable condition.
11. Oversized material that is produced shall be broken down.
12. The quarry site shall be left in a condition free from overburden and debris. Access roads to the quarry, benches, and the quarry floor shall be cleared of unused shot rock and dirt at the termination of use. Access roads shall be waterbarred to provide drainage as specified in Exhibit H and blocked as directed by STATE. Unused shot rock material that is produced shall be piled in the vicinity of the quarry as directed by STATE. Dirt, overburden, and reject material shall be hauled to designated waste area.
13. Proper winterization and storm-water control measures such as waterbarring, drainage, utilization of filter bales, mulching and/or blocking access shall be constructed and maintained to protect the watershed and Project Work, as directed by STATE.
14. Apply seed to the waste area, as specified in Exhibit K.

EXHIBIT G
CULVERT SPECIFICATIONS

All culvert materials shall be furnished and installed by PURCHASER, unless otherwise specified in the Contract. All culverts shall be constructed of corrugated polyethylene. Polyethylene culverts shall be double-walled and meet the requirements of AASHTO M-294-11, Type S, or ASTM F2648.

Lengths of individual culvert sections shall be not less than 10 feet, unless otherwise provided for in special instructions. The shortest culvert section length shall be placed at the inlet end.

Joining shall be done with bands of like material and corrugations. Manufacturers' instructions shall be followed for prefabricated pipe assembly. Polyethylene joints shall be made with split couplings, corrugated to engage the culvert corrugations, and shall engage a minimum of 4 corrugations, 2 on each side of the culvert joint.

Culverts shall be located according to the alignment and grade as shown on the Plan and Profile, and/or as staked in the field, or as specified in special instructions. The STATE Representative shall determine final culvert locations and stake the locations in the field prior to installation.

Cross drain culverts on road grades in excess of 3 percent shall be skewed at least 30 degrees from perpendicular to the road centerline, except that cross drain culverts at the low point of dips in roads shall not be skewed.

Culvert grade shall slope away from ditch grade at least 5 percent unless otherwise specified.

The foundation and trench walls for all culverts shall be free from logs, stumps, limbs, stones, and other objects which would dent or damage the culvert. The culvert trench shall be excavated 3 culvert diameters wide to permit compaction and working on each side of the culvert. Tamping shall be done in 6-inch lifts, 1 culvert diameter each side of the culvert to 95 percent density or over. Bedrock shall be excavated as required to provide a uniform foundation for the full length of the culvert. Minimum bedding depth shall be 6 inches.

A bedding of granulated material or crushed rock as specified shall be placed to provide a wide band of support and to transmit the load from above evenly over the entire length of the culvert.

Backfill shall consist of granulated material, crushed rock, or job-excavated soil free of stumps, limbs, rocks, or other objects which would damage the culvert.

Transporting of the culvert shall be done carefully. Dragging or allowing free fall from trucks or into trenches shall not be permitted.

Minimum height of cover over top of culvert to subgrade when road is to be rockered shall be 12".

The ends of each culvert shall be free of logs and debris which would restrict the free flow of water. The intake end of relief culverts shall be provided with a sediment catching basin 3 feet in diameter at the bottom. The outlet end of any culvert which would allow water to erode embankment soil shall be provided with an energy dissipator, half round, or other approved slope protection device. Construct lead-off ditches away from culvert outlets where the slope gradients restrict the free flow of water.

Tamping is required on all culverts.

The intake end of culverts shall be marked by installing a 5 foot long, rust-resistant painted steel fence post two feet into the ground, within 6 inches of the inlet on the downgrade side.

EXHIBIT G
 CULVERT SPECIFICATIONS

All culverts scheduled for replacement shall become property of the PURCHASER be removed from STATE land in the same project period in which replacement occurred.

A manufacturer's certification that the product was manufactured, tested, and supplied in accordance with this specification shall be furnished to STATE upon request.

CULVERT LIST

CULVERT NO.	DIAMETER (Inches)	LENGTH (Feet)	ROAD SEGMENT Point to Point	STATION
1	18	40	A to B	105+22
2	18	40	A to B	105+75
3	18	40	A to B	161+04
4	18	40	A to B	210+13
5	18	50	A to B	212+23
6	18	30	A to B	296+29
7	18	30	A to B	352+82
8	18	30	A to B	361+70
9	24	40	A to B	374+46
10	18	30	A to B	395+67
11	18	30	A to B	407+67

TOTAL LENGTHS BY DIAMETER	
18 INCH	24 INCH
360 Feet	40 Feet

EXHIBIT H
 WATERBAR SPECIFICATIONS

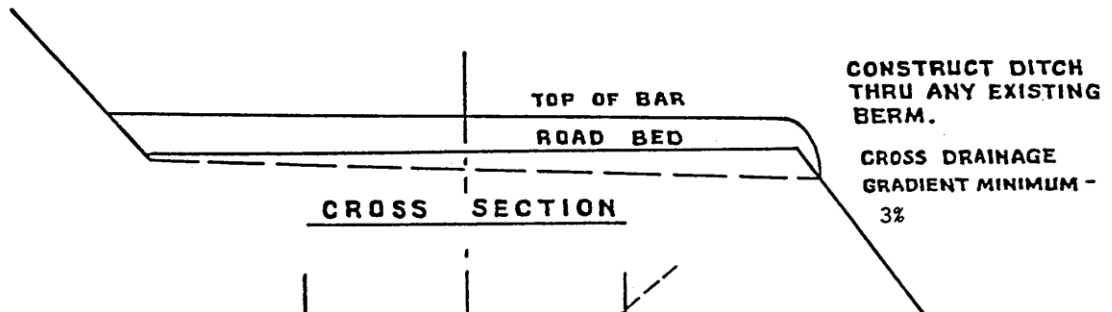
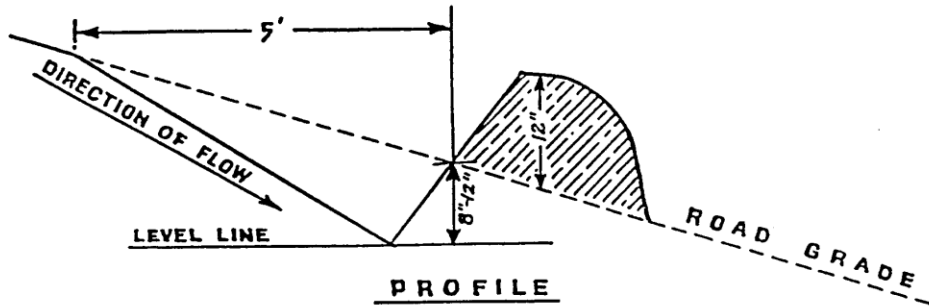

SPACING OF WATERBARS

ROAD GRADE	DISTANCE
≤ 5%	600'
6-10%	300'
11-15%	150'
16-20% or greater	100'

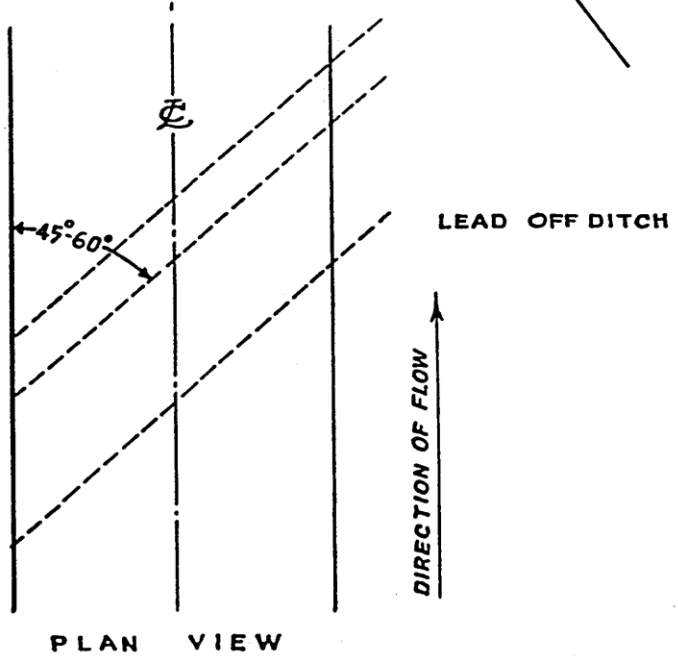

**WATERBAR SPECIFICATIONS
 FOR CROSS DITCHING #298**

EXHIBIT I

TANK TRAP SPECIFICATIONS

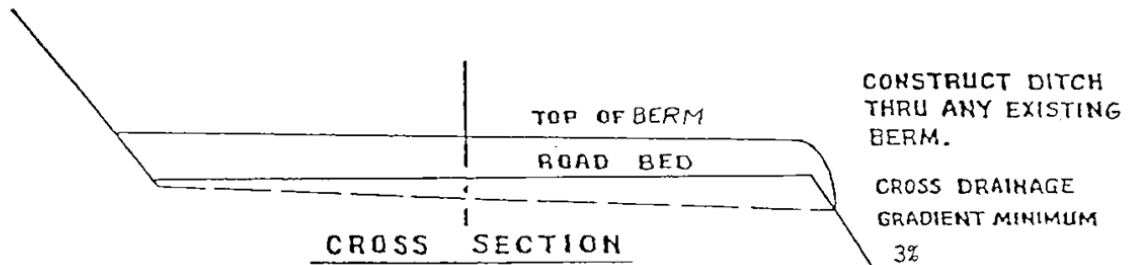
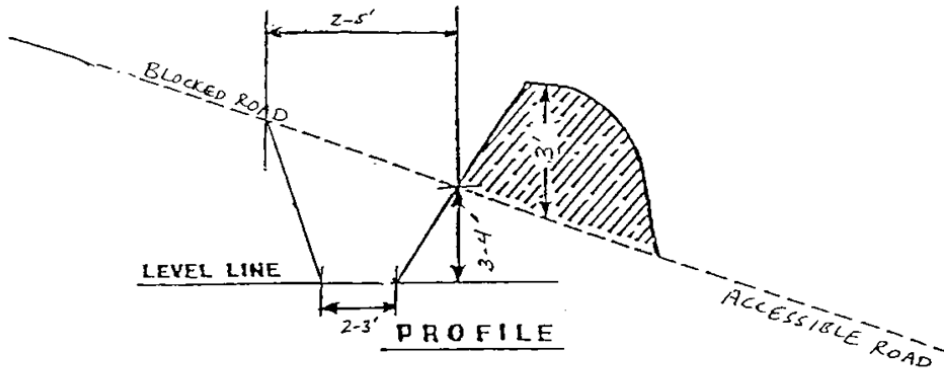

Tank trap shall be installed in a "V" shape. It should be sloped to drain with a relief ditch through the down slope edge of the road. The trench shall be behind the berm for approaching traffic.

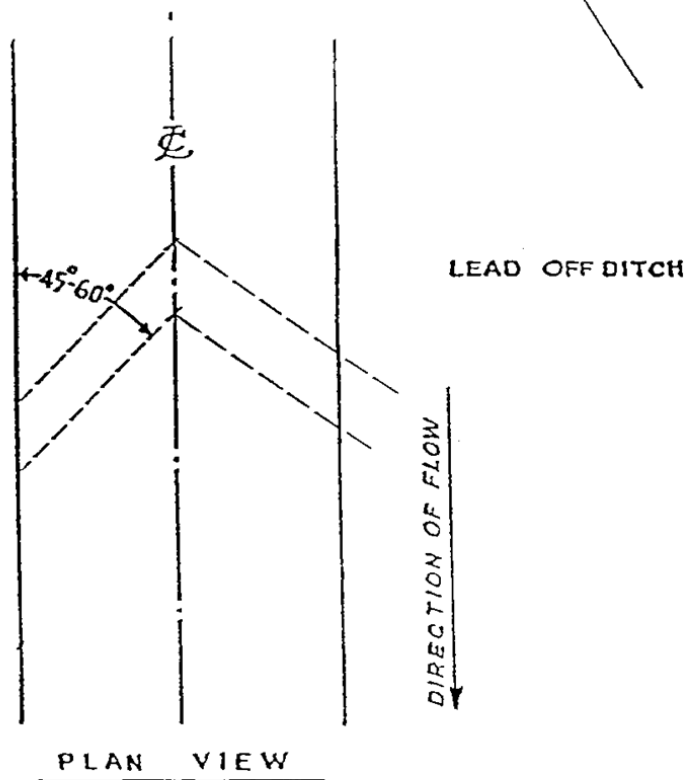

TANK TRAP SPECIFICATIONS

Timber Sale Contract
No. 341-15-34
Mill Bound

EXHIBIT J

SPECIFICATIONS FOR LANDING SLASH PILING

Piling Slash/ covering Piles: All piles shall be as compact as possible. Piles shall be built to a height of 3 to 4 feet and then covered to prevent water from reaching the Slash. Each pile shall be covered with 100 square feet of polyethylene plastic sheeting. The plastic sheeting shall be clear Polyethylene Plastic 4 mil gauge. PURCHASER shall supply the materials used for covering the Slash. Additional woody debris shall be piled on top of the covered piles to complete the piling, as directed by STATE.

Placement of Piles: Piles shall be placed in a location to minimize damage from burning to standing green trees and Snags. Piles shall be placed as follows:

- (a) No less than 30 feet from any Snags or green trees, unless otherwise approved by STATE.
- (b) Cull log segments suitable for firewood shall be piled separately from Slash at a distance of no closer than 20 feet from the Slash piles.

EXHIBIT K

SEEDING AND FERTILIZING

This work shall consist of preparing seedbeds and furnishing and placing required seed and fertilizer.

Seeding Seasons. Seeding shall be performed only from March 1 through June 15 and August 15 through October 15. Seeding materials shall not be applied during windy weather or when the ground is excessively wet or frozen. Areas of disturbed soil shall be seeded by the end of the project period in which work was started. PURCHASER shall notify STATE 24 hours prior to seeding.

Soil Preparation. Areas to be seeded that have been damaged by erosion or other causes shall be restored prior to seeding. All areas to be seeded shall be finished and then cultivated to provide a reasonably firm, but friable seedbed. A minimum of 1/2 inch of surface soil shall be in a loose condition.

Application Methods for Seed and Fertilizer

Dry Method. Mechanical seeders, seed drills, landscape seeders, cultipacker seeders, fertilizer spreaders or other approved mechanical seeding equipment shall be used to apply the seed and fertilizer in the amounts and mixtures specified. Hand-operated seeding devices may be used when seed and fertilizer are applied in dry form.

Application Rates for Seed and Fertilizer

Seed listed below shall be applied at the following rates per acre:

SPECIES	Lb./Acre	MIXTURE	PURE LIVE SEED	Repellent
Fine Fescue	12	40%	98%	0
Annual Ryegrass	6	20%	98%	0
Perennial Ryegrass	9	30%	98%	0
White Dutch Clover	3	10%	98%	0

Fertilizer: Chemical analysis shall be 16-20-0 and shall be applied at the rate of 200 pounds per acre. Fertilizer shall not be applied within 100 feet of streams.

Seeding will be considered acceptable when all other specified requirements in Exhibits L have been completed and a healthy, uniform, close stand of grass has been established, unless otherwise approved in writing by STATE.

State Timber Sale Contract
No. 341-15-34
Mill Bound

EXHIBIT L
MULCHING

This work shall consist of furnishing and placing required mulch. Mulch shall consist of straw that is free of noxious weeds.

Mulching Period. Straw mulch shall be applied within 24 hours of spreading grass seed and fertilizer.

Application Rates for Mulch

Place straw mulch to a reasonably uniform thickness of $\frac{3}{4}$ to $1\frac{1}{4}$ inches. This rate requires between 1 and $1\frac{1}{2}$ tons of dry mulch per acre.

EXHIBIT M

OHV TRAIL FILTER FOR MC TRAIL

NOT TO SCALE

Blocking materials minimum size should be 3'x3', either boulders, root wads, or cull logs. Blocking materials shall be touching and extend to the edges of roadway, or skid trail.

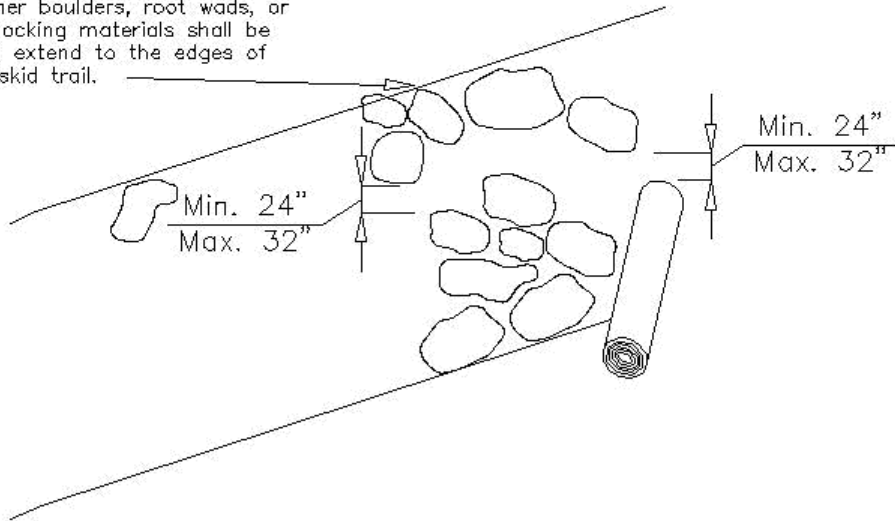

PLAN VIEW

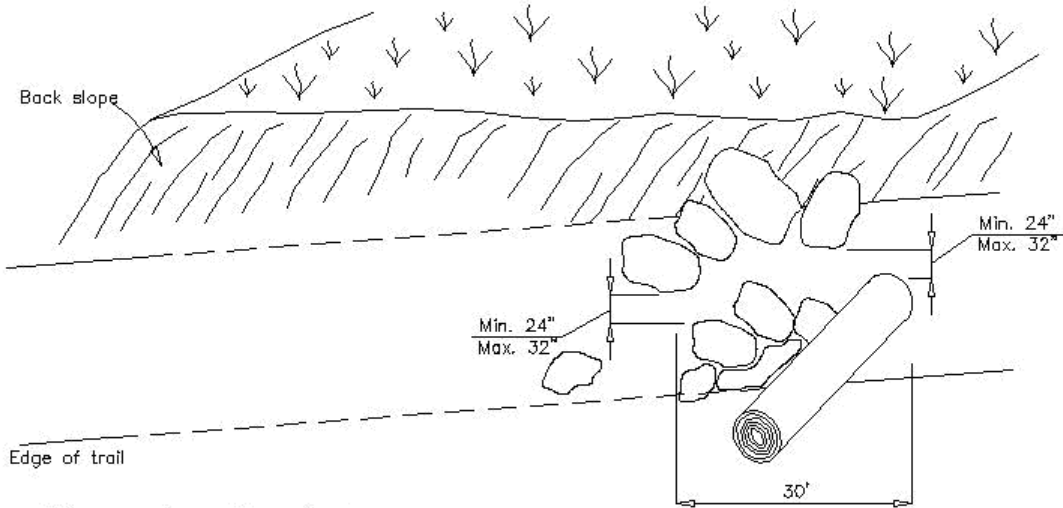

Chicane maximum 32" spacing for through path entrance, and exit.
6'-8' curve radius through chicane.
Overall length of chicane should be 30'. Boulders used as blocking material should be buried to 1/3 of original height.

PROFILE

EXHIBIT N

TYPICAL CROSS SECTION VIEW OF SIDECAST PULLBACK AND ROAD REALIGNMENT

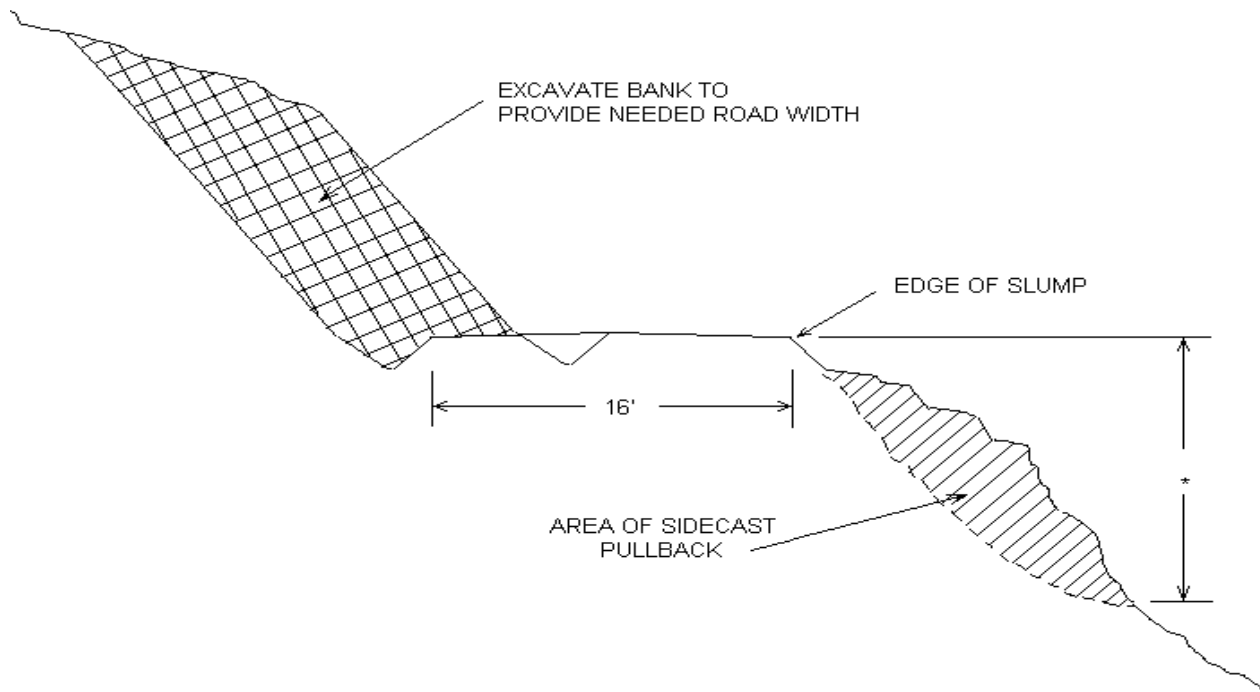

(No Scale)

* As marked in field

EXHIBIT O

ROCK QUARRY TEST DRILLING REQUIREMENTS

- 1) PURCHASER shall notify STATE a minimum of 48 hours prior to beginning any operations. A STATE Representative shall be present during test drilling to monitor results, issue instructions, determine test hole locations and depths. The representative also shall certify hours of operation or acceptance of work when required under contract.
- 2) Work scheduling shall provide for continual operation until contract work is completed, unless interrupted by poor weather, fire closures, or other uncontrollable circumstances, equipment breakdowns shall be repaired without undue delay, and provision shall be made for replacement of equipment to prevent prolonged delays. Testing operations shall not be allowed from October 1 to April 30, or during any other period when operations might damage sites or affect stream flows. Any exception to these instructions must be authorized in writing by STATE.
- 3) The hydraulic rock drill shall be a crawler-type in the 40,000 pound class or greater, with a minimum penetration rate of 120 feet per hour while drilling a 4"-6" bore hole, in overburden, fractured rock and solid rock.
- 4) The operator must be experienced in operating hydraulic rock drills on rock test drilling operations, be able to operate the drill proficiently, and operate in the area as directed by STATE.
- 5) Support including transport, other equipment, replacements, supplies, maintenance, and repairs shall be furnished as required to complete work; and shall be furnished without cost to STATE.
- 6) Test holes shall be drilled to determine mass attitudes of rock strata, rates of drill advancement, depths of overburden and other pertinent information.
- 7) Each test hole shall be staked and assigned an individual number. Test holes shall be drilled for a maximum distance of 60 feet in vertical, horizontal and/or other directions, as directed by STATE.
- 8) STATE may elect to change the test drilling locations at the quarry sites. However, no more than a total of 22 hours of hydraulic rock drill time will be utilized. Should STATE determine that not all hours are needed, PURCHASER shall pay to STATE \$225 per hour for each hour not used.
- 9) Access road construction may be required. Access roads shall be constructed by the PURCHASER using small excavator. All routes and location of access roads shall be flagged and approved by STATE prior to construction. No more than a total of 5 hours of small excavator time will be utilized. Should STATE determine that not all hours are needed, PURCHASER will be directed to complete related quarry projects.
- 10) Upon completion of test drilling at each site, waterbar all excavator and test equipment access roads and reestablish drainage ditches, as directed by STATE.

EXHIBIT P

ROAD VACATING SPECIFICATIONS

PURCHASER shall vacate the Edwards Creek culvert at point K as shown on Exhibit A. Specific objectives for this project include:

- (1) Tree Removal. Cut or remove only the trees necessary to access the project area and to facilitate vacating operations, as directed by STATE. Timber shall NOT be removed as Designated Timber, unless located within posted timber sale boundaries or right-of-way boundaries.
- (2) Fill Removal and Stream Channel Development. Remove fill to the natural stream course levels. Stream channel shall be excavated/developed to natural widths and original orientation. Developed stream banks shall be sloped at natural contours or no steeper than 1½:1, as directed by STATE.
- (3) Remove drainage structure. Divert all live water prior to removing the drainage structure. Removed structures, including concrete and asphalt, shall become property of Contractor and be hauled to an approved refuse site off of STATE land in the same project period in which work occurred.
- (4) Use of Excavated Materials. Excavated materials shall be shall be hauled to a designated waste area, spread, and compacted.

Woody Debris shall be hauled to the waste area and piled separately.

- (5) Erosion Control. Apply grass seed and straw mulch to excavated material and bare soils, in accordance with the specifications in Exhibits K and L.
- (6) Dry Conditions. All work shall be performed during dry conditions acceptable to STATE.
- (7) Block Road. Road shall be blocked prior to stream channel according to specifications in Exhibit I.

PART IV: OTHER INFORMATION

State Timber Sale Contract
No. 341-15-34
Mill Bound

WRITTEN PLAN

SALE NAME: Mill Bound

PROTECTED WATERS: Boundary Creek (Large Fish Bearing), Headquarters Camp Creek (Large Fish Bearing), Stretch Creek (Medium Fish Bearing), and Miller Creek (Small and Medium Fish Bearing).

Definitions: Stream buffer: at least 100 feet horizontal distance from the high water mark on each side of the stream.

LOCATIONS: Portions of Sections 32, 33, and 34, T2S, R 7W and Sections 3, 4, and 5, T3S, R7W, W.M., Tillamook County, Oregon.

ACTIVITIES: Cable logging lines hanging over Type F stream.

PROTECTION MEASURES:

- All trees in the RMA are reserved from cutting.
- Cable yarding lines will be pulled out of the RMA prior to rigging the next yarding road.
- Work will only be done during in-water work period (July 1 – September 15). Wood placement work outside this period will only be allowed if a written waiver is obtained from the ODFW and is submitted to ODF. ODFW will need a minimum of 14 days to process such waiver.
- If trees or logs fall or slide into a stream channel they will not be limbed, bucked, or removed without prior approval from ODF.
- Cable lines will be an average of at least 150 feet apart where they extend over or through the Type F stream and buffer.

ACTIVITIES: Log Placement in Type F stream.

PROTECTION MEASURES:

- Work will only be done during in-water work period (July 1 – September 15) Wood placement work outside this period will only be allowed if a written waiver is obtained from the ODFW and is submitted to ODF. ODFW will need a minimum of 14 days to process such waiver.
- Work will be done during dry (no-rain) conditions.
- Work in stream channel will be limited to necessary wood placement.
- Work will be supervised by ODFW employee or ODF Aquatic and Riparian Specialist.
- RMA disturbance will be minimized through route planning and limiting stream crossings to those necessary to access the site.
- All areas of bare or disturbed soil will be seeded with an approved seed mix.

PREPARED BY: Bryan Huck, Tillamook Contracts Unit
May 13, 2014

State Timber Sale Contract
No. 341-15-34
Mill Bound

WRITTEN PLAN

PROTECTED WATERS: Edwards Creek, medium type "F" stream.

LOCATION: NW ¼, Sec. 2, T2S, R8W, W.M., Tillamook County, Oregon.

Activity: Removal of culvert and associated materials within 100 feet of medium Type F stream.

Protection measures:

All necessary measures will be taken to prevent sediment from entering "live" streams, including but not limited to:

- Work will be performed only during dry weather periods and low water stream flows. Operations will cease when rain or periods of high stream flows results in a visual increase in turbidity.
- Turbidity shall not exceed 10% above natural stream turbidities as a result of work.
- Oil spill response materials will be on site before work begins.
- Stream water shall be diverted prior to removing culverts/fills.
- No in-stream activity will be conducted prior to July 1 or after September 15 without prior approval from the Oregon Department of Fish and Wildlife.
- Machine activity in stream shall be kept to a minimum. Disturbance of existing vegetation shall be kept to a minimum.
- All practical erosion control measures shall be taken to minimize sedimentation in the waters of the STATE. All areas of disturbed soil resulting from project work, including fill slopes, cut banks, access trails and waste areas will be grass seeded and mulched. **Fertilizer shall not be used.**
- Fill slopes will be constructed at a 1 ½ to 1 fill width-to-height ratio.

Date: June 25, 2014

Prepared by: Reid Brown

NOTICE OF TRANSFER OF STATE TIMBER

Instructions

629:-Form-301-010

Complete Section 1. Mark the box which applies to you/your company in Section 2. Complete Section 3 and obtain signatures.

SECTION 1

On _____, state timber sale purchaser (Transferor)
_____, sold, exchanged or otherwise transferred to
_____, (Transferee) state timber originating from State
Timber Sale Contract No. _____.

Transferee hereby certifies that they:

- (a) Will not export the unprocessed state timber which is the subject of this transaction;
- (b) Will not sell, transfer, exchange or otherwise convey the unprocessed timber which is the subject of this transaction to any other person without first obtaining a like certification from that person; and
- (c) Are not prohibited by OAR's 629-31-005 through 045 from purchasing state timber or logs directly from the State Forester, or this is a sale of Western Red Cedar for domestic processing.

SECTION 2

- Have not exported unprocessed timber originating from private lands in Oregon in the last 24 months.
- This is a sale of hardwood logs for domestic processing.
- This is a sale of Western Red Cedar for domestic processing.
- This is a sale of pulp logs or cull logs processed at domestic pulp mills, domestic chip plants or other domestic operations for the purpose of conversion of the logs into chips.

SECTION 3

The parties understand that falsely entering into this certification, or failure to comply with the terms of this certification is a violation of the Forest Conservation and Shortage Relief Act of 1990 and OAR Chapter 629, Division 31, and is subject to any and all penalties contained therein.

Transferor:

Transferee:

Signed

Signed

Title

Title

Dated

Dated

[Note: For the purpose of this form, the definition of unprocessed timber is the same as in OAR 629-31-005]

Mail To: State Forester
2600 State Street
Salem, OR 97310