

# PART III: EXHIBITS

State Timber Sale Contract  
No. 341-10-87  
North Coal

EXHIBIT B

Page 1 of 3  
629-Form 341-203  
Revised 06/97

## OREGON DEPARTMENT OF FORESTRY

### TIMBER SALE OPERATIONS PLAN

(See Page 2 for instructions)

Date Received by STATE: \_\_\_\_\_

(5) State Brand Information (complete):



(1) Contract No.: 341-10-87

(2) Sale Name: North Coal

(3) Contract Expiration Date: October 31, 2011

Project Completion Dates: \_\_\_\_\_

(4) Purchaser: \_\_\_\_\_

(6) Purchaser Representatives:

Projects: \_\_\_\_\_

Phone: \_\_\_\_\_

Cell/Other

Phone: \_\_\_\_\_

Home: \_\_\_\_\_

Projects: \_\_\_\_\_

Phone: \_\_\_\_\_

Cell/Other

Phone: \_\_\_\_\_

Home: \_\_\_\_\_

Projects: \_\_\_\_\_

Phone: \_\_\_\_\_

Cell/Other

Phone: \_\_\_\_\_

Home: \_\_\_\_\_

Projects: \_\_\_\_\_

Phone: \_\_\_\_\_

Cell/Other

Phone: \_\_\_\_\_

Home: \_\_\_\_\_

Logging: \_\_\_\_\_

Phone: \_\_\_\_\_

Cell/Other

Phone: \_\_\_\_\_

Home: \_\_\_\_\_

Logging: \_\_\_\_\_

Phone: \_\_\_\_\_

Cell/Other

Phone: \_\_\_\_\_

Home: \_\_\_\_\_

Logging: \_\_\_\_\_

Phone: \_\_\_\_\_

Cell/Other

Phone: \_\_\_\_\_

Home: \_\_\_\_\_

Logging: \_\_\_\_\_

Phone: \_\_\_\_\_

Cell/Other

Phone: \_\_\_\_\_

Home: \_\_\_\_\_

(7) State Representatives:

Projects: \_\_\_\_\_

Phone: \_\_\_\_\_

Cell/Other

Phone: \_\_\_\_\_

Home: \_\_\_\_\_

Logging: \_\_\_\_\_

Phone: \_\_\_\_\_

Cell/Other

Phone: \_\_\_\_\_

Home: \_\_\_\_\_

(8) Name of Subcontractors & Starting Dates:

Projects:	No(s) _____ - _____	Date: _____	Phone: _____
	No(s) _____ - _____	Date: _____	Phone: _____
	No(s) _____ - _____	Date: _____	Phone: _____
	No(s) _____ - _____	Date: _____	Phone: _____

Logging: Felling _____	Date: _____	Phone: _____
Yarding: _____	Date: _____	Phone: _____

(9) Comments:

(10) Operations Map: Attach a copy of timber sale Exhibit "A" or other suitable map which plainly shows the items listed on the instruction sheet.

EXHIBIT B  
OPERATIONS PLAN  
INSTRUCTION SHEET FOR OPERATIONS PLAN

**SUBMIT ONE COPY OF PLAN TO STATE**





Operations shall be limited to the work shown in the plan until a revised plan or supplemental plan is submitted covering additional work. Compliance with this plan is not in lieu of compliance with any federal requirements related to the federal Endangered Species Act. If STATE has prepared a required Forest Practices Act (FPA) "Written Plan" for operations, PURCHASER shall comply with all provisions of the Written Plan.

**Item No. (from Page 1)**

- (5) All sales require you to use a brand furnished by STATE. If the State brand has not been assigned when the plan is submitted, it will be furnished and assigned later. Complete drawing. If more than one brand is assigned to the sale, complete both drawings.
- (6) The contract requires you to have a designated representative available on the sale area or work location who is authorized to receive in your behalf any notice or instruction given by STATE and to take action in regard to performance under the contract. If logging and project work is widely separated, a representative is required for each.
- (7) The STATE representative will be designated when your plan is approved and is the person who will inspect and issue instructions regarding performance.
- (8) Show names of subcontractors to be used for any or all phases of the operations. If subcontractors are not known, or are changed later, give notification to the STATE representative prior to commencement of work by subcontractor.

Show projected dates for commencement of both projects and logging. If projected dates need to be changed at a later date, notification must be given to the STATE representative by supplemental plan or otherwise, prior to commencement of such operations.

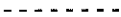
- (10) The STATE representative will furnish extra copies of Exhibit "A" of the contract for your use in preparing the operations map. The map shall use the following legend and show:
  - 1. Landing locations, approximate setting boundaries, and probable sequence of logging the settings. Number the settings in sequence.
  - 2. Locations of spur roads planned for construction, other than those required by the timber sale contract. Provide spur road specifications.
  - 3. Location of proposed tractor yarding roads. Show if and how marked on the ground.
  - 4. Location of temporary stream crossings.
  - 5. List the sequence of performing project work.
  - 6. Location of rock sources - attach pit development plans.

-  Cable landing, with numbers for sequence.
-  Tractor landing with alphabetical sequence.
-  Approximate setting boundary.
-  Spur truck roads.
-  Tractor yarding roads.
-  Temporary stream crossings.

Original: Salem  
cc: District File  
Purchaser

EXHIBIT B  
OPERATIONS PLAN

Completion Timeline

Indicate on the appropriate timeline below, the dates by which you plan to complete the work as required under this contract. The purpose of this section is to develop a plan that will ensure you complete the work as required, and meet the interim completion date(s) and contract expiration date. This plan is incorporated and made a part of the contract. When, in the opinion of STATE, operations are not commencing in a manner that meets the intent of this plan, you may be placed in violation of contract and your operations suspended until an amended plan is submitted and approved by STATE.

**Projects**

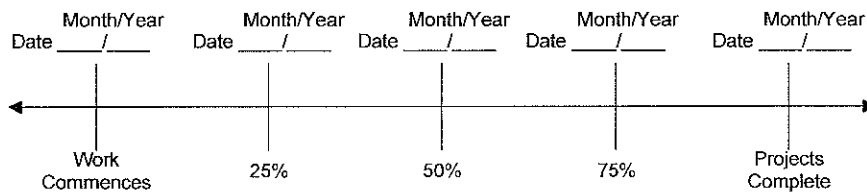

**Harvest & Other Requirements**

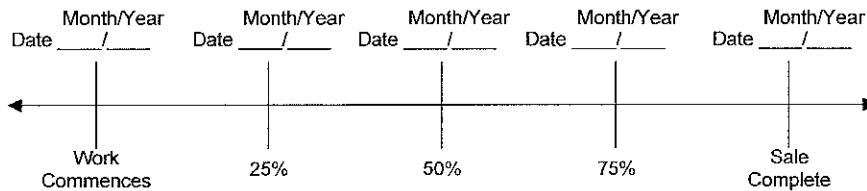

The Federal Endangered Species Act (ESA) prohibits a person from taking any federally listed threatened or endangered species. Taking under the federal ESA may include alteration of habitat. The STATE's approval of this plan does not certify that the PURCHASER's operation under the plan is lawful under the federal ESA. As provided in the timber sale contract, PURCHASER's must comply with all applicable state, federal, and local laws.

PURCHASER's compliance with this plan is not in lieu of compliance with any federal requirements related to the federal Endangered Species Act.

APPROVED: Date: \_\_\_\_\_

SUBMITTED BY:  
PURCHASER

STATE OF OREGON - DEPARTMENT OF FORESTRY

\_\_\_\_\_  
Title

\_\_\_\_\_  
Title

Original: Salem  
cc: District File  
Purchaser

EXHIBIT C

SCALING INSTRUCTIONS -- LOCATION APPROVAL -- BRAND INFORMATION

(1) ORIGINAL REGISTRATION  Date \_\_\_\_\_  
 REVISION NUMBER \_\_\_\_\_  Date \_\_\_\_\_  
 CANCELLATION  Date \_\_\_\_\_

(2) TO: \_\_\_\_\_  
 (Third Party Scaling Organization)

(3) FROM: Tillamook (06) Phone (503) 842-2545  
 (State Forestry District)  
 Address 5005 Third Street, Tillamook, OR 97141

(4) PURCHASER: \_\_\_\_\_  
 Mailing Address: \_\_\_\_\_  
 Phone Number: \_\_\_\_\_

(12) NOTICE OF CANCELLATION OF BRAND:  
 Effective Date: \_\_\_\_\_

State Forester's Representative \_\_\_\_\_

(13) SALE NAME North Coal

COUNTY Tillamook

(14) STATE CONTRACT NUMBER 341-10-87

(15) STATE BRAND REGISTRATION NUMBER \_\_\_\_\_

(16) STATE BRAND INFORMATION:  
 (COMPLETE)

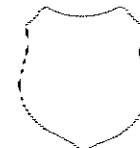

(5) MINIMUM SCALING SPECIFICATIONS			CLASS		
SPECIES	SCALING DIAMETER INCHES	*NET SCALE VOLUME	PER MBF	** SUM	SUB
*					

\* Apply minimum volume test to whole logs over 40' Westside; 20' Eastside.  
 \*\* Sum (if indicated): see instructions and explain in Item (19).

(6) WESTSIDE SCALE: YES  NO   
 Use Region 6 actual taper rule. Logs over 40'.

(7) EASTSIDE SCALE:  YES   
 Use Region 6 actual taper rule. Logs over 40'.

(8) Weight Scale Sample  YES   
 (6) - (8), pink log load receipts

(9) Weight Sale  YES

(10) Per Load  YES   
 (9) and (10), yellow log load receipts

(17) PAINT REQUIRED: YES   
 COLOR Orange

(18) SPECIAL REQUESTS
PEELABLE CULL (all species)
<b>NO DEDUCTIONS ALLOWED FOR MECHANICAL DAMAGE</b>
ADD-BACK VOLUME - Deductions due to delay
OTHER:

(19) REMARKS \_\_\_\_\_  
 \_\_\_\_\_  
 \_\_\_\_\_  
 \_\_\_\_\_  
 \_\_\_\_\_  
 \_\_\_\_\_

Operator's Name (Optional inclusion by District): \_\_\_\_\_

(20) SIGNATURES:  
 \_\_\_\_\_  
 Purchaser or Authorized Representative Date  
 \_\_\_\_\_  
 State Forester Representative Date

(11) APPROVED SCALING LOCATIONS	Species	Yard	Truck	Weight

**Notify the District within one hour when branding or painting is inadequate for quick identification, the receipts are missing, not correctly or completely filled out, and/or when logs presented for scaling are impossible to scale accurately.**

EXHIBIT C

INSTRUCTIONS FOR FORM 343-307 (rev. 10/08)

- (1) Check appropriate box. REVISION NUMBER requires comments. CANCELLATION requires Item (12). Complete date.
- (2) Designate Third Party Scaling Organization (TPSO).
- (3) State District office, address and phone.
- (4) Enter Purchaser's business name, address, and phone number as it appears on the Contract.
- (5) Minimum Scaling Specifications. Review Section 2040 or 2045, "Log Removal," of the Contract. Species, or combined species can be separate entries. Information serves as a basis for scaling (see also Items (16) thru (18)), and is required to show existence on the sale. **SUM** (lump sum material). **SUB** (submerchantable material). SUB, as used by the State, references that material containing at least 10 bf (net) but less than the lower merchantable net volume limit or grade requirements for other merchantable (Per MBF) entries. Per MBF, SUM, and SUB must be indicated by checking the appropriate column. Species with the same specifications and value are combined into one entry. Per MBF and SUB require scaling therefore complete specifications. SUM need not be scaled, hence no specifications. Loads containing only SUM are to be ticketed if so instructed in Item (19). Mixed loads of SUM, Per MBF and/or subspecies will always be scaled.
- (6) Westside – Region 6 actual taper segment scale. Check Yes or No. Special Service Rules on file with TPSO. See: Segment Scaling and Grading of Long Logs -- All Species -- State Forestry Department Scaling Practices (Westside).
- (7) Eastside – Region 6 actual taper/taper table segment scale. Special Service Rules on file with TPSO. See: Segment Scaling and Grading of Long Logs -- All Species -- State Forestry Department Scaling Practices (Northwest Log Rules Eastside). Items with \* follow U.S. Forest Service Eastside rules.
- (8) Weight Scale Sample – Check box if sale is to be a Weight Scale Sample. All specifics for handling, scaling and processing will be attached or explained in the Remarks section Item (19).
- (9) Weight Sale – Check box if sale is to be sold as a weight sale. Processing procedures from approved locations to TPSO's will be explained in the Remarks section of Item (19).
- (10) Per Load – Check box if volumes on sale are per load. Specific instructions for handling and processing will be fully explained in the Remarks section of Item (19).
- (11) Show scaling locations only applicable to TPSO. Location name should appear as it does on the ODF Approved Scaling Location web site: [http://www.odf.state.or.us/DIVISIONS/management/asset\\_management/ScalingLocation.asp](http://www.odf.state.or.us/DIVISIONS/management/asset_management/ScalingLocation.asp) Locations with scaling and processing directions specific to their location should be on a separate form. Species should be identified if not capable of receiving "all" species. Check appropriate box for either: yard, truck scale, or weight. Refer to the web site listed above for the locations approval status.
- (12) When logging and hauling is complete, recall branding hammers, date and sign where indicated, check CANCELLATION box in Item (1), and send to TPSO.
- (13) Enter sale name and county
- (14) Enter sale Contract number.
- (15) Enter Oregon's State Brand Registry Number (required).
- (16) Show brand assigned to timber sale. One brand only. If more than one brand is assigned to the sale: (1) make separate form for each brand and (2) on each form, explain and show other brand(s) in the Remarks section Item (19).
- (17) Check yes for Paint Required and designate "Orange" for color. Non required removal volumes may sometimes require blue paint.
- (18) Special Requests. These are requests that will be applied to ODF timber sales. If "Other" is indicated, it must contain a description and any necessary comments.
- (19) Use this space to designate any weight conversion factors, per load volumes, weight scale sample instructions or any other explanations to clarify scaling or processing requirements. If additional scaling locations are approved, prepare another form showing all (old and new) locations. Check REVISION box at top of form and explain under remarks. Route as indicated.
- (20) Require purchaser to sign and date completed form.

EXHIBIT D  
 FOREST ROAD SPECIFICATIONS

SUBGRADE WIDTH	SURFACED WIDTH	POINT TO POINT	STATION TO STATION	DRAINAGE	DITCH TOP WIDTH (Feet)	DITCH CONFIGURATION (U, V, TRAPAZOID)	DITCH DEPTH FROM FINISHED SURFACE (Feet)
16	*	A to B	0+00 to 0+60	Outsloped	---	---	---
16	12	A to B	0+60 to 30+75	Ditched	3	V	1
16	12	A to B	30+75 to 32+65	Outsloped	---	---	---
16	12	A to B	32+65 to 101+75	Ditched	3	V	1
16	12	A to B	101+75 to 103+30	Outsloped	---	---	---
14 feet	12 Feet	C to D	0+00 to 1+00	Outsloped	---	---	---
15 feet	---	C to D	1+00 to 10+00	Outsloped	---	---	---

\* Existing Junction Width

CLEARING. This work shall consist of clearing, removing, and disposing of all trees, Snags, Down Timber, brush, surface objects, and protruding obstructions within the clearing limits.

Where clearing limits have not been marked, the "Road Brushing Specifications" in Exhibit D shall apply. Clearing debris shall not be placed or permitted to remain in or under any road embankment sections. Clearing debris shall not be left lodged against standing trees.

All danger trees, leaners, and Snags outside the clearing limits which could fall and hit the road shall be felled.

GRUBBING. This work shall consist of the removal or digging out of stumps and protruding objects.

All stumps shall be completely removed within the limits of required grubbing. Stumps overhanging cutslopes shall be removed. Grubbing debris shall not be placed or permitted to remain in or under any road embankment sections. Grubbing debris shall not be left lodged against standing trees. Grubbing classifications are as follows:

New construction and reconstruction - From the top of the cutslope to the toe of the fill.

Improvements - 4 feet back from the shoulder of the subgrade or the ditch, whichever is widest, or as marked in the field.

Trees outside the clearing limits shall not be felled unless approved in writing by STATE.

CLEARING AND GRUBBING DISPOSAL. Scatter through openings in the timber outside of the cleared right-of-way, except areas where end-haul is required.

EXHIBIT D  
FOREST ROAD SPECIFICATIONS

EXCAVATION. Excavation and grading shall not be done when weather and/or ground conditions are such that damage will result to existing subgrade or cause excessive erosion.

Excavation shall conform to STATE-engineered lines, grades, dimensions, and plans when provided.

All suitable excavated material shall be used where possible for the formation of fills, shoulders, and drainage structure backfills. Embankment materials shall be free of woody debris, brush, muck, sod, frozen material, and other deleterious materials

Unless road design plans show otherwise, all roads shall be on a balanced cross section, except when the slope is over 50 percent, the road shall be on full bench for the width specified.

Excess excavation shall not be sidecast where material will enter a stream course or where material will accumulate in areas deemed a high landslide hazard location by STATE.

ROAD WIDTH LIMITATIONS. PURCHASER shall obtain advance written approval from STATE to construct the road to a greater width than specified. Extra subgrade width shall be required for:

Fill Widening. Add to each fill shoulder 1 foot for fills 3 feet to 6 feet high; 2 feet for fills over 6 feet high.

Curve Widening. Widen the inside shoulder of all curves as follows: 400 divided by the radius of the curve equals the amount of extra width.

DRAINAGE

Ditch. Construct ditch as specified in Exhibit D. Subgrade shall be crowned at 4 to 6 percent. Construct ditchouts away from subgrade at locations marked in the field.

Outslope. Road subgrade shall be outsloped at 4 to 6 percent.

TURNOUTS. Increase roadbed width an additional 8 feet for both subgrade and surfacing. Length shall be at least 25 feet, or as staked on the ground, plus 25-foot approaches at each end.

Location: Intervisible but not greater than 750 feet.

GRADING

Rock

Common -

Common - turnpike (level) section

Back Slopes

Vertical to 1/4:1

3/4:1

2:1

Fill Slopes

Not steeper  
than 1 1/2:1

Top of cutslope shall be rounded.

LANDINGS. Landings shall be constructed as posted in the field, no less than 50 feet wide and no more than 70 feet wide. Surface shall be crowned for drainage.

TURNAROUNDS. Increase subgrade width an additional 30 feet for a length of 16 feet with 20' radius returns at locations marked in the field.

EXHIBIT D  
ROAD BRUSHING SPECIFICATIONS



Clearing Limits

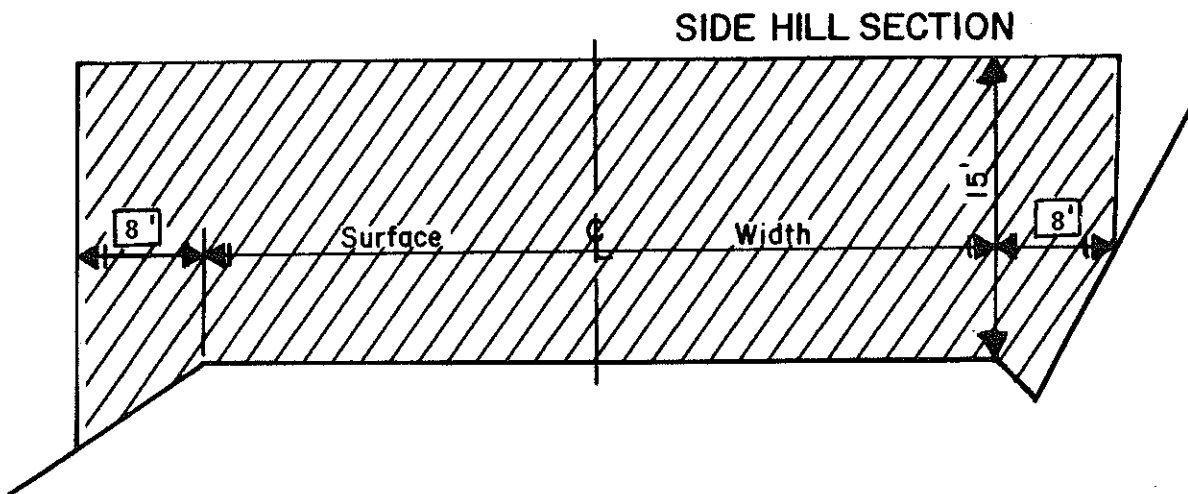

REQUIREMENTS

Unless otherwise approved in writing by STATE, brush and trees less than 6 inches DBH shall be cut to a height of 6 inches or less above the ground surface or obstructions such as rocks or existing stumps. Brushing on project road segments shall be completed prior to subgrade approval. Trees shall not be felled unless a portion of the bole is within the clearing limits.

Debris resulting from the brushing operation shall be removed from the roadway, cutslope, ditches, and water courses within 72 hours and may be scattered downslope from the road or placed in other stable locations, unless otherwise approved by STATE.

Trees outside the clearing limits shall not be felled unless approved in writing by STATE.



EXHIBIT D  
 END-HAULING REQUIREMENTS

POINT TO POINT	STA. TO STA.	WASTE AREA LOCATION	WASTE AREA TREATMENT
A to B*	0+00 to 103+30	Scattered in stable location outside of clearing limits	None
C to D	0+00 to 1+00	A to B (78+90)	1
C to D	6+50 to 8+50	8+50 to 9+50	2

\*Ditchline Material

End-Haul Areas General Requirements

Material shall not be intentionally side cast.

Ditchline material shall not be swept across roadway

Clearing and grubbing debris shall be end hauled between stations 0+00 to 1+00, segment C to D.

When blasting is required, it shall be accomplished using timing devices, delayed charges, low intensity shots, or other suitable means to contain all material within the road prism.

Containment

Full containment: The amount of material lost over the outside edge of the road shall not exceed 6 inches in depth measured perpendicular to the natural ground slope. Pioneer excavation shall be removed by digging, loading, and hauling rather than by pushing or scraping methods.

Tree bases and stumps may have up to 12 inches of material directly above them. Any amount of material exceeding the containment requirements shall be removed by whatever means necessary and end-hauled to a designated waste area.

Waste Area Location

As shown on Exhibit A and as marked in the field.

Waste Area Treatment

- (1) Deposit at waste area, spread evenly, compact, and provide adequate drainage. Pile woody debris separate from other waste material.
- (2) Waste material shall be utilized for fill material for road construction as specified in Exhibit G. Scatter woody debris outside clearing limits in stable location.

EXHIBIT E  
 ROAD SURFACING

ROAD SEGMENT:	A to B		STATIONS:	0+00	to	52+80		
Application	Rock Size and Type	Location	Compacted Depth	Volume (CY) per	Number of Units	Curve Widening (CY)	Approx. Total (CY)	
Road Rock	Crushed 1"-0"	0+00 to 4+00	4 "	station 22.500	4.00	10	100	
Road Rock	Crushed 1"-0"	97+00 to 103+30	2 "	station 11.111	6.30	10	80	
Turnouts	Crushed 1"-0"	A to B	4 "	TO 10	1		10	
Turnouts	Crushed 1"-0"	A to B	2 "	TO 10	1		10	
Application	Rock Size and Type	Location	Approx. Total (CY)					
Junction	Crushed 1"-0"	0+00 to 0+30	30					
ROAD SEGMENT:	C to D		STATIONS:	0+00	to	1+00		
Application	Rock Size and Type	Location	Compacted Depth	Volume (CY) per	Number of Units	Curve Widening (CY)	Approx. Total (CY)	
Road Rock	Pit-Run	0+00 to 1+00	12 "	station 70.0	1.00	10	80	

Roads shall be uniformly graded and approved by STATE prior to rocking.

For typical cross section, turnout and turnaround see Forestry Department Drawing Nos. 351-C, 351-D and TOTA-1 at the Forestry Department district office.

EXHIBIT E  
 CRUSHED ROCK SPECIFICATIONS

Materials. The material shall be well graded and consistent.

Quality and Grading Requirements. The stone base materials shall be crushed rock. River gravel shall not be used.

If material is specified as durable, it must meet the following test requirements:

Hardness - Test Method AASHTO T 96: 30% Maximum

Durability - Test Method ODOT TM 208  
 Passing No. 20 Sieve: 30% Maximum

2	--
1.5	100
1	95-100
3/4	75-95
1/4 or #4	50-75
#10	25-50

1 Inch	
Sieve size	Percent Passing

<u>For 6"-0" Pit-Run</u>	Passing	10" sieve	100%
	Passing	6" sieve	60-85%
	Passing	3" sieve	30-50%
	Passing	1/4" sieve	10% maximum

Control of pit-run gradation shall be by visual inspection by STATE. Pit-run shall be reasonably free of organic material and shall not contain an excessive amount of oversized (cobbles or boulders) or undersized (clay, silt or sand) particles.

The referenced sieve shall have square openings as set forth in AASHTO M 92, Woven Cloth Series. The determinations of size and gradings shall be as set forth in AASHTO T 27.

EXHIBIT E  
ROCK ACCOUNTABILITY

**PURCHASER shall obtain STATE approval for subgrades prior to rocking.** Rocking must be done only when weather conditions are acceptable to STATE, and must be suspended when muddy water could enter streams.

Rock accountability shall be determined by depth measurement. STATE shall be given 24 hours' notice prior to rocking.

Depth Measurement. Road rock shall be spread and compacted according to the depths specified in Exhibit E. Truck measure volumes are given, but shall not limit the amount of rock spread.

Depth shall be determined in the most compacted area of the surface cross section. If additional rock is required because of insufficient depth, it shall be added by truck measure to those areas that were slighted. The conversion from compacted yardage to truck yardage is 1.3 multiplied by the compacted yardage equals truck yardage.

The depth of compacted aggregates shall not vary more than 1 inch from the depth specified in Exhibit E. The average depth for each road segment shall be the specified depth or greater.

Turnouts shall have a surfaced area of at least 44 square yards each at the depths shown in Exhibit E.

Junctions shall have a surfaced area as is at the compacted depths specified in Exhibit E.

Curve Surfacing. Extra surface width shall be required for the inside of all curves as follows: 400 divided by the radius of the curve equals the amount of extra width to be surfaced at the depths shown in Exhibit E.

EXHIBIT E

COMPACTION AND PROCESSING REQUIREMENTS

Subgrade. Subgrade surfaces of the road segments listed below shall be graded and compacted prior to rocking. Compaction shall be accomplished by traveling all surfaces from shoulder to shoulder until visible deformation ceases, or in the case of a sheepsfoot roller, the roller "walks out." At least 3 passes shall be made over the entire width and length of the road. A pass is defined as traveling a road section in one direction and then back over that same section again. Compaction shall be accomplished by using the approved equipment listed below or others approved by STATE.

ROAD SEGMENT	COMPACTION EQUIPMENT OPTIONS
C to D	Vibratory Roller

Fills. Embankments and fills shall be placed in (approximately) horizontal layers not more than 8 inches in depth. Each layer shall be separately, and thoroughly, compacted. Compaction equipment shall be operated over the entire width of each layer until visible deformation of the layers ceases or, in the case of a sheepsfoot roller, the roller "walks out." At least 3 passes shall be made over the entire width and length of each layer. A pass is defined as traveling a fill layer in one direction and then back over that same layer again.

Placing individual rocks or boulders with more depth than the allowed layer thickness shall be permitted, provided the embankment will accommodate them. Such rocks and boulders shall be at least 6 inches below the subgrade. They shall be carefully distributed and the voids filled with finer material, forming a dense and compacted mass. Compaction shall be accomplished by using the approved equipment listed below or others approved by STATE:

ROAD SEGMENT	COMPACTION EQUIPMENT OPTIONS
C to D	Crawler Tractor

Pit-Run Rock. Pit-run surfacing rock shall be spread on roads with a crawler tractor and continuously walked-in. Rock spreading shall begin at nearest point from the rock source and progress toward the end of the project, unless otherwise approved in writing by STATE. Compaction shall be accomplished by using the approved equipment listed below or others approved by STATE:

Rock shall be outsloped at 4 to 6 percent unless otherwise specified.

ROAD SEGMENT	COMPACTION EQUIPMENT OPTIONS
C to D	Vibratory Roller

EXHIBIT E

COMPACTION AND PROCESSING REQUIREMENTS

Crushed Rock. The rock shall be uniformly mixed and spread in layers on the approved roadbed. Each layer of crushed rock shall be moistened or dried to a uniform moisture content suitable for maximum compaction and compacted in layers not to exceed 6 inches in depth. When more than 1 layer is required, each shall be shaped and compacted before the succeeding layer is placed. Any irregularities or depressions that develop during compaction of the top layer shall be corrected by loosening the material at these places and adding or removing material until the surface is smooth and uniform. Each layer shall be compacted with a minimum of 3 passes over the entire width and length of the road. A pass is defined as traveling a road section in one direction and then back over that same section again. Compaction shall be accomplished by using the approved equipment listed below or others approved by STATE:

Rock shall be compacted and processed during the same project period it is spread, unless otherwise approved in writing by STATE.

Rock shall be crowned at 4 to 6 percent unless otherwise specified.

ROAD SEGMENT	COMPACTION EQUIPMENT OPTIONS
A to B – 0+00 to 4+00 and 97+00 to 103+30	Vibratory Roller

Existing Crushed Rock. The existing rock shall be unearthed to a minimum depth of 4 inches or to 1 inch below the bottom of potholes, whichever is greater. The existing rock shall then be uniformly mixed and moistened or dried to a uniform moisture content suitable for maximum compaction and compacted. Any irregularities or depressions that develop during compaction shall be corrected by loosening the material at these places and adding or removing material until the surface is smooth and uniform. The existing rock shall be compacted with a minimum of 3 passes over the entire width and length of the road. A pass is defined as traveling a road section in one direction and then back over that same section again. Compaction shall be accomplished by using the approved equipment listed below or others approved by STATE:

Existing crushed rock shall be compacted and processed after completion of all project work and log hauling, unless otherwise approved in writing by STATE.

Rock shall be crowned at 4 to 6 percent unless otherwise specified.

ROAD SEGMENT	COMPACTION EQUIPMENT OPTIONS
A to B – 0+00 to 30+75	Vibratory Roller

COMPACTION EQUIPMENT OPTIONS

Vibratory Rollers. The drum shall have a smooth surface, a diameter not less than 48 inches, a width not less than 58 inches, and a turning radius of 15 feet or less. Vibration frequency shall be regulated in steps to 1400, 1500, and 1600 VPM, corresponding to engine speeds of 1575, 1690, and 1800 RPM. The centrifugal force developed shall be 7 tons at 1600 VPM. It shall be activated by a power unit of not less than 25 horsepower. The vibratory roller shall be self-propelled and operated at speeds ranging from 0.9 miles to 1.8 miles per hour, as directed by STATE.

Crawler Tractors. D-7 Caterpillar or equivalent or larger.

EXHIBIT F  
CULVERT SPECIFICATIONS

All culvert materials shall be furnished and installed by PURCHASER, unless otherwise specified in the Contract. Culvert shall be constructed of corrugated polyethylene. Culverts shall conform to the material and fabricating requirements of the "Standard Specifications for Highway Construction" prepared by the Highway Division of the Oregon State Department of Transportation. Polyethylene culverts shall also be double walled and meet the requirements of AASHTO M-294-901, Type S. Corrugation types and shapes other than those meeting the above minimum Highway requirements, shall be approved in writing by STATE.

Culverts shall be located according to the alignment and grade as shown on the Plan and Profile, and/or as staked in the field, or as stipulated in special instructions.

The STATE Representative shall determine final culvert locations and stake the locations in the field prior to installation.

Culvert grade shall slope away from ditch grade at least 5 percent unless otherwise specified.

The foundation and trench walls for all culverts shall be free from logs, stumps, limbs, stones, and other objects which would dent or damage the pipe. The culvert trench shall be excavated 3 pipe diameters wide to permit compaction and working on each side of the pipe. Tamping shall be done in 6-inch lifts, 1 pipe diameter each side of the pipe to 95 percent density or over. Bedrock shall be excavated as required to provide a uniform foundation for the full length of the culvert. Minimum bedding depth shall be 6 inches.

A bedding of granulated material or crushed rock as specified shall be placed to provide a wide band of support and to transmit the load from above evenly over the entire length of the pipe.

Backfill shall consist of granulated material, crushed rock, or job-excavated soil free of stumps, limbs, rocks, or other objects which would damage the pipe.

Transporting of the pipe shall be done carefully. Dragging or allowing free fall from trucks or into trenches shall not be permitted.

Joining shall be done with bands of like material and corrugations. Manufacturers' instructions shall be followed for prefabricated pipe assembly.

Polyethylene joints shall be made with split couplings, corrugated to engage the pipe corrugations, and shall engage a minimum of 4 corrugations, 2 on each side of the pipe joint.

When joints are employed, the longest length of pipe shall be placed at the outlet end.

A manufacturer's certification that the product was manufactured, tested, and supplied in accordance with this specification shall be furnished to the State's Contract Administrator upon request.

EXHIBIT F  
CULVERT SPECIFICATIONS

Minimum height of cover over top of culvert to subgrade when road is to be rocked shall be 12". Minimum vertical cover for other designs shall be as specified by STATE.

Lengths of individual culvert sections shall be not less than 10 feet, unless otherwise provided for in special instructions. The shortest culvert section length shall be placed at the inlet end.

The ends of each culvert shall be free of logs and debris which would restrict the free flow of water. The intake end of relief culverts shall be provided with a sediment catching basin 3 feet in diameter at the bottom. The outlet end of any culvert which would allow water to erode embankment soil shall be provided with an approved slope protection device. Construct lead-off ditches away from culvert outlets where the slope gradients restrict the free flow of water.

CULVERT LIST

CULVERT NO.	DIAMETER (Inches)	LENGTH (Feet)	ROAD SEGMENT POINT TO POINT	STATION
1	18	30	A to B	0+60

The intake end of culvert shall be marked by installing a 5 foot long, painted steel fence post two feet into the ground, within 6 inches of the inlet on the downgrade side.

Tamping is required on culvert.

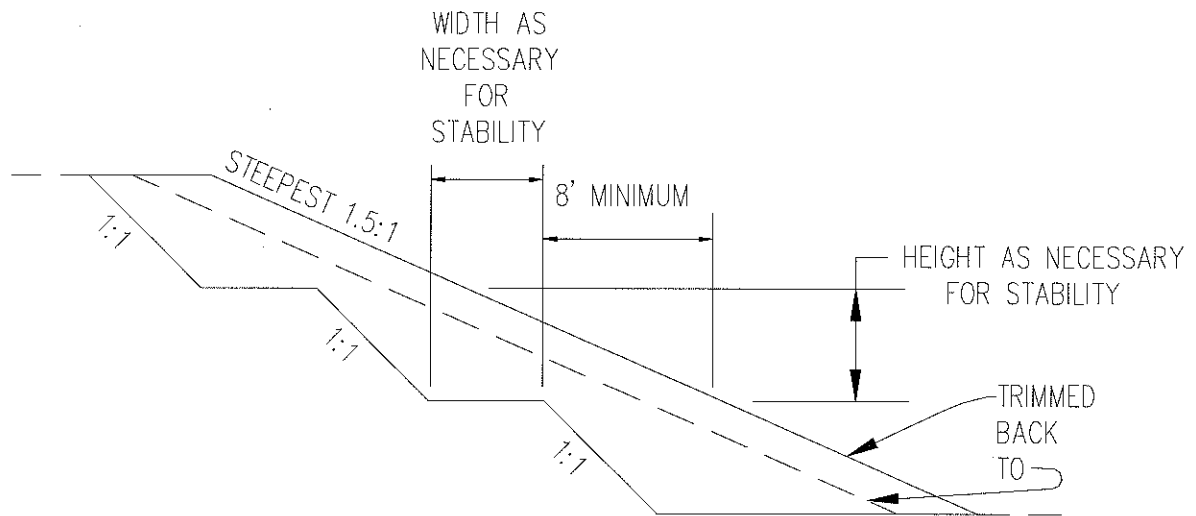

EXHIBIT G

FILL CONSTRUCTION SPECIFICATIONS

(no scale)

ALL TEMPORARY EARTH SLOPES SHALL COMPLY WITH OSHA REQUIREMENTS. AREAS TO RECEIVE STRUCTURAL FILL THAT HAVE A SLOPE GREATER THAN 5 HORIZONTAL FEET TO 1 VERTICAL FOOT SHALL HAVE HORIZONTAL BENCHES AND KEYWAYS CUT INTO THE FILL AREAS PRIOR TO PLACING THE NEW FILLS. ALL FILL MATERIAL SHALL BE PLACED AS STRUCTURAL FILL BEYOND 1.5H:1V SLOPE AND THEN BE TRIMMED BACK TO A 1.5H:1V SLOPE SO THAT COMPACTED FILL IS EXPOSED ON THE FACE OF THE SLOPE (SEE DETAIL BELOW).



DETAIL: BENCHING AND SIDEHILL EMBANKMENT FILL CONSTRUCTION

THE STATE SHALL BE CONTACTED TO OBSERVE THE FINAL CUT AND FILL SLOPE CONFIGURATIONS AND CONDITIONS TO COMMENT ON THE NEED FOR FURTHER GRADING OR SLOPE STABILIZATION METHODS BASED ON THE FINAL GRADING CONDITIONS.

ONCE OBSERVED BY THE STATE, EROSION CONTROL MEASURES SHALL BE APPLIED TO THE GRADED SLOPES.

EXHIBIT H  
 WATERBAR SPECIFICATIONS

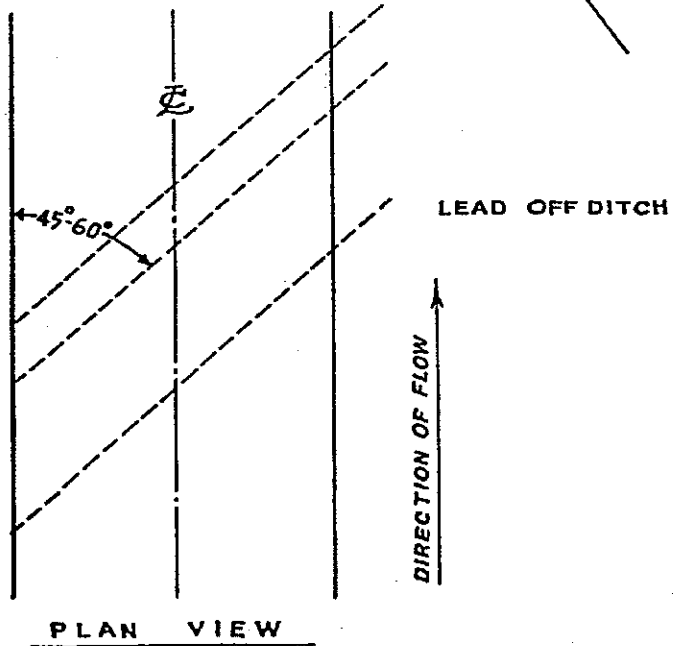
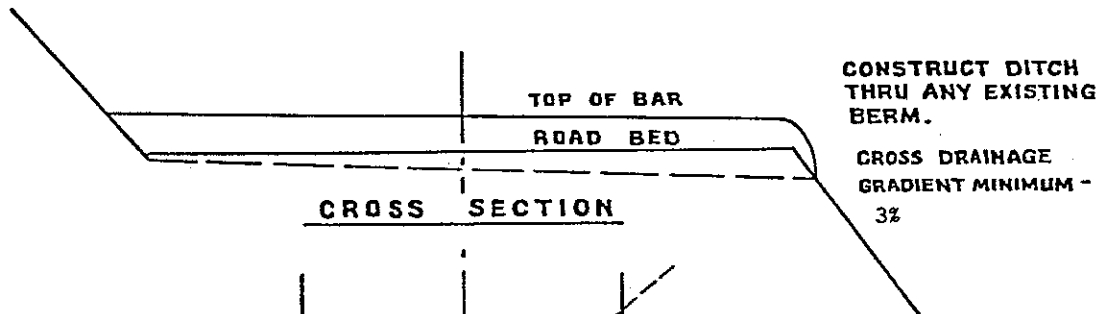
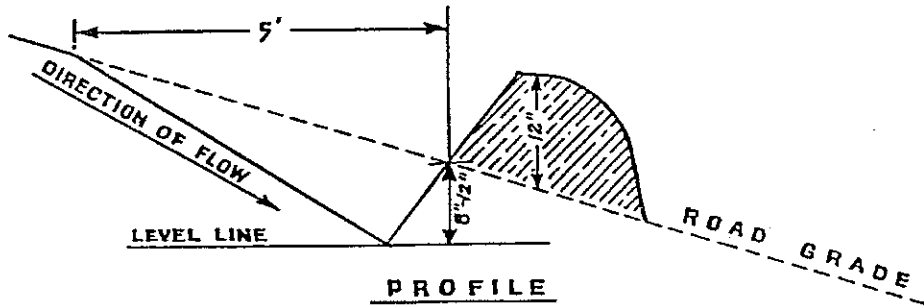

SPACING OF WATERBARS	
ROAD GRADE	DISTANCE
≤ 5%	600'
6-10%	300'
11-15%	150'
16-20% or greater	100'

**WATERBAR SPECIFICATIONS  
 FOR CROSS DITCHING #298**

EXHIBIT I

SEEDING AND FERTILIZING

This work shall consist of preparing seedbeds and furnishing and placing required seed and fertilizer.

Seeding Seasons. Seeding shall be performed only from March 1 through June 15 and August 15 through October 15. Seeding materials shall not be applied during windy weather or when the ground is excessively wet or frozen. Areas of disturbed soil shall be seeded by the end of the project period in which work was started. (PURCHASER shall notify STATE 24 hours prior to seeding.)

Soil Preparation. Areas to be seeded that have been damaged by erosion or other causes shall be restored prior to seeding. All areas to be seeded shall be finished and then cultivated to provide a reasonably firm, but friable seedbed. A minimum of 1/2 inch of surface soil shall be in a loose condition.

Application Methods for Seed and Fertilizer

Dry Method. Mechanical seeders, seed drills, landscape seeders, cultipacker seeders, fertilizer spreaders or other approved mechanical seeding equipment shall be used to apply the seed and fertilizer in the amounts and mixtures specified. Hand-operated seeding devices may be used when seed and fertilizer are applied in dry form.

Application Rates for Seed and Fertilizer

Seed listed below shall be applied at the following rates per acre:

<u>Species</u>	<u>Lb./Acre</u>	<u>Mixture</u>	<u>Pure Live Seed</u>	<u>Poison and/or Repellent</u>
Fine Fescue	12	40%	98%	0
Annual Ryegrass	6	20%	98%	0
Perennial Ryegrass	9	30%	98%	0
White Dutch Clover	3	10%	98%	0

Fertilizer: Chemical analysis shall be 16-20-0 and shall be applied at the rate of 300 pounds per acre.

Seeding will be considered acceptable when all other specified requirements in Exhibits I been completed and a healthy, uniform, close stand of grass has been established, unless otherwise approved in writing by STATE.